

GPIB Command Syntax

for

E1963A W-CDMA Mobile Test Application Revision A.07

E6703C W-CDMA Lab Application Revision C.02

1000-1906



Agilent Technologies

Notice

Information contained in this document is subject to change without notice.

All Rights Reserved. Reproduction, adaptation, or translation without prior written permission is prohibited, except as allowed under the copyright laws.

This material may be reproduced by or for the U.S. Government pursuant to the Copyright License under the clause at DFARS 52.227-7013 (APR 1988).

Agilent Technologies, Inc.
Learning Products Department
24001 E. Mission
Liberty Lake, WA 99019-9599
U.S.A.

Contents

| | |
|-----------------------|----|
| ABORt | 10 |
| AFGenerator | 11 |
| CALCulate:SMONitor | 12 |
| CALibration | 13 |
| CALL:AICHannel | 13 |
| CALL:ATTFlag | 13 |
| CALL:AWGNoise | 14 |
| CALL:BCCHannel | 15 |
| CALL:CCPChannel | 20 |
| CALL:CELL2:CCPChannel | 20 |
| CALL:CELL2:CLPControl | 21 |
| CALL:CELL2:CPIChannel | 21 |
| CALL:CELL2:DPCHannel | 21 |
| CALL:CELL2:OCNSource | 21 |
| CALL:CELL2:POWer | 22 |
| CALL:CELL2:SCODE | 22 |
| CALL:CELL2:TOFFset | 22 |
| CALL:CHANnel | 22 |
| CALL:CLPControl | 23 |
| CALL:COMPressed | 24 |
| CALL:CONNected | 26 |
| CALL:CONTRol | 28 |
| CALL:COUNt | 28 |
| CALL:COUNt:DTMonitor | 29 |
| CALL:CPIChannel | 30 |
| CALL:CPNumber | 30 |
| CALL:CVALue | 31 |
| CALL:DATA:PING | 31 |
| CALL:DPCHannel | 32 |
| CALL:END | 35 |
| CALL:FDDTest | 36 |
| CALL:HANDoff | 38 |
| CALL:IDENtity | 38 |
| CALL:LACode | 38 |
| CALL:MNCCode | 39 |
| CALL:MS:IP:ADDRess | 39 |
| CALL:MS:LOOPback | 39 |
| CALL:MS:POWer | 39 |
| CALL:MS:REPorted | 40 |
| CALL:OCNSource | 43 |
| CALL:OPERating | 43 |
| CALL:ORIGinate | 43 |

Contents

| | |
|-------------------|----|
| CALL:PAging | 44 |
| CALL:PCTPower | 44 |
| CALL:PICHannel | 45 |
| CALL:PLOGging | 45 |
| CALL:POWer | 46 |
| CALL:PSDomain | 46 |
| CALL:RACode | 46 |
| CALL:RBSSetup | 46 |
| CALL:RFGenerator | 46 |
| CALL:RLC | 47 |
| CALL:SCODE | 47 |
| CALL:SECurity | 48 |
| CALL:SERVice | 49 |
| CALL:SETup | 50 |
| CALL:SHANdoff | 51 |
| CALL:SMSservice | 54 |
| CALL:SRBearer | 59 |
| CALL:STATus | 60 |
| CALL:SYSTem | 64 |
| CALL:TMSI | 64 |
| CALL:TOTal:POWer | 64 |
| CALL:TRIGger | 64 |
| CALL:UINterferenc | 64 |
| CALL:UPLink | 65 |
| CALL:WAVEform | 67 |
| FETCh:AFANalyzer | 68 |
| FETCh:FSTability | 70 |
| FETCh:SAUDio | 71 |
| FETCh:SMONitor | 73 |
| FETCh:WACLeakage | 73 |
| FETCh:WBError | 74 |
| FETCh:WBLerror | 74 |
| FETCh:WCDomain | 75 |
| FETCh:WCPower | 76 |
| FETCh:WCTFormat | 77 |
| FETCh:WDPAnalysis | 79 |
| FETCh:WILPower | 80 |
| FETCh:WIQTuning | 81 |
| FETCh:WOBWidth | 83 |
| FETCh:WOOPower | 84 |
| FETCh:WPDison | 85 |
| FETCh:WPPAnalysis | 86 |

Contents

| | |
|--------------------------------|-----|
| FETCh:WSEMask | 87 |
| FETCh:WTDPower | 88 |
| FETCh:WTPower | 88 |
| FETCh:WWQuality | 89 |
| INITiate | 92 |
| READ | 95 |
| RFAnalyzer | 97 |
| RFGenerator:OUTPut | 97 |
| SETup:CONTinuous | 97 |
| SETup:AFAnalyzer | 98 |
| SETup:FSTability | 100 |
| SETup:SAUDio | 101 |
| SETup:SMONitor | 103 |
| SETup:WACLeakage | 106 |
| SETup:WBERror | 108 |
| SETup:WBLerror | 109 |
| SETup:WCDomain | 109 |
| SETup:WCPower | 110 |
| SETup:WCTFormat | 111 |
| SETup:WDPAnalysis | 112 |
| SETup:WILPower | 114 |
| SETup:WIQTuning | 115 |
| SETup:WOBWidth | 116 |
| SETup:WOOPower | 117 |
| SETup:WOOSynch | 118 |
| SETup:WPDison | 119 |
| SETup:WPPAnalysis | 120 |
| SETup:WSEMask | 121 |
| SETup:WTDPower | 122 |
| SETup:WTPower | 123 |
| SETup:WWQuality | 124 |
| STATus:OPERation | 125 |
| STATus:PRESet | 125 |
| STATus:QUEStionable | 126 |
| Status Byte Register | 126 |
| Standard Event Status Register | 127 |
| SYSTem:APPLication | 128 |
| SYSTem:AUDio | 129 |
| SYSTem:BEEPer | 129 |
| SYSTem:COMMunicate | 129 |
| SYSTem:CONFigure | 130 |
| SYSTem:CORRection | 130 |

Contents

| | |
|----------------------------------|-----|
| SYSTem:CURRent:TA | 130 |
| SYSTem:DATE | 130 |
| SYSTem:ERRor? | 131 |
| SYSTem:FATal | 131 |
| SYSTem:MEASurement:RESet | 131 |
| SYSTem:PRESet | 131 |
| SYSTem:REGister | 131 |
| SYSTem:ROSCillator | 131 |
| SYSTem:STATus | 132 |
| SYSTem:SYNChronized | 133 |
| SYSTem:TIME | 133 |
| SYSTem:TZONE | 133 |
| SYSTem:UTC | 133 |
| IEEE 488.2 Common Commands | 133 |

GPIB Syntax for E1963A and E6703C

Description

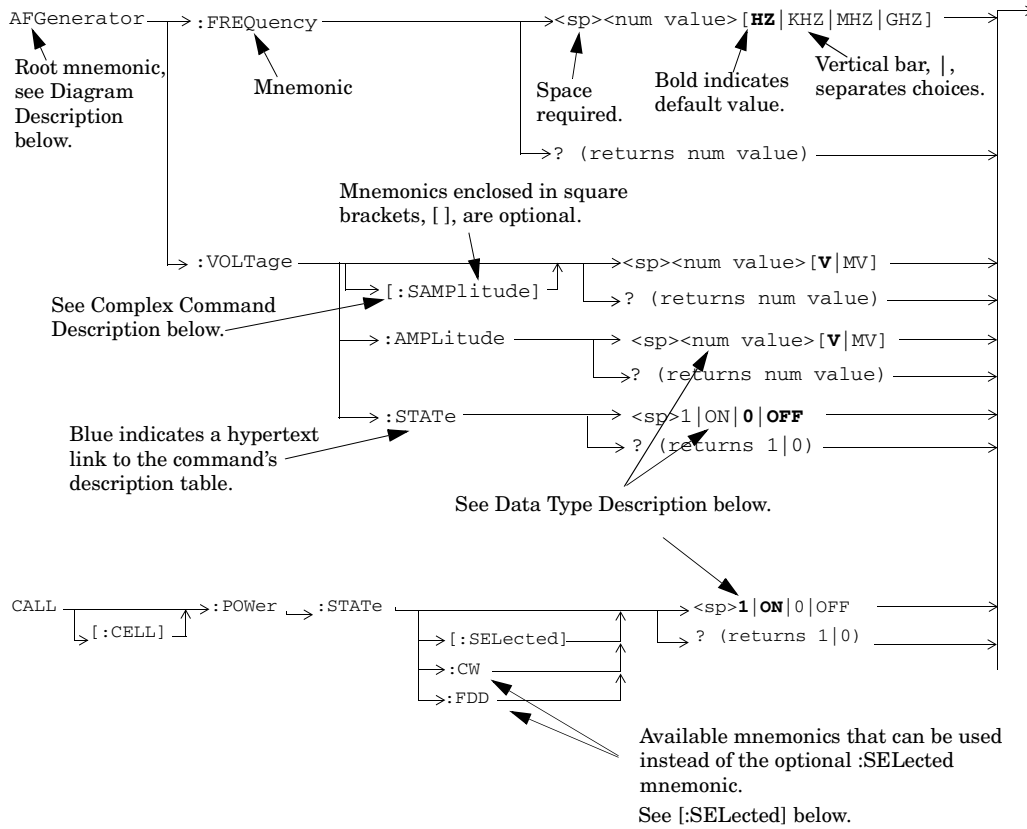

GPIO Syntax for E1963A and E6703C

Diagram Description

Mnemonics are connected by lines. Each line can be followed in only one direction, as indicated by the arrow at the end of the line. Any combination of mnemonics that can be generated by starting at the root mnemonic and following the line in the direction of the arrow is syntactically correct.

The uppercase letters of a mnemonic represent the short form of the mnemonic, whereas the long form of a mnemonic is the short form followed by the lowercase letters. The test set accepts either the long form or the short form of the mnemonic. The mnemonics that are inside square brackets are optional. That is, a command operates the same whether or not the mnemonic in square brackets is used in the command.

The drawings show the proper use of spaces. Where spaces are required they are indicated by <sp>, otherwise no spaces are allowed between mnemonics.

Complex Command Description

Complex commands are valuable because they set the state of the parameter and a value for that parameter. For example, the command in the above figure that contains the mnemonic [:SAMPLitude] is a complex command because sets the state to ON as well as the amplitude. You can use parameters such as amplitude, frequency, gain, number, time, and value as a complex command. Refer to the specific command for the parameter that applies.

Data Type Description

| | |
|-----------------------------|---|
| num value | Integer, float or scientific values. For example, CALL:POWer -55.5 CALL:POWer -5.55E+001 CALL:CHANnel 525 |
| string | Characters. The string will often need to be enclosed in single or double quotes, depending upon your programming environment. For example, CALL:UPLink:PRACHannel:ASUBchannels '111111111111' The string returned by the test set is enclosed by double quotes. |
| choice1 choice2 choice3 | Specific character choices. For example, CALL:OPERating:MODE D2KTest SYSTem:COMMunicate:GPIO:DEBug ON |

[:SElected] Mnemonic

The [:SElected] Mnemonic is an optional mnemonic that implies a current selection on the test set. Often there are other mnemonics that can be used in place of the [:SElected] mnemonic to configure a setting that is not the currently selected configuration on the test set. The mnemonics that can replace the [:SElected] mnemonic are listed in parentheses separated by vertical bars (|) in the description table title. An example of a command that contains the [:SElected] mnemonic is shown in the following table.

CALL[:CELL]:POWER:AMPLitude[:SElected]

CALL[:CELL]:POWER:AMPLitude:(CW|FDD) ←

Available mnemonics that can be use instead of the optional [:SElected] mnemonic.

| | |
|----------|--|
| Function | Sets/queries the desired cell power level. (See "Cell Pow information about desired versus current power levels.) The optional [:SElected] keyword in this command spec queried applies to the current system type (see "CALL[:C settings for the CW operating mode are independent of operating modes. |
| Setting | Range: (This is the range of settings accepted, see "Cell I Ranges" for the actual hardware range of the source <ul style="list-style-type: none"> FDD: -165 dBm/3.84MHz to +37 dBm/3.84MHz CW: -177 dBm to +46 dBm |

GPiB Syntax for E1963A and E6703C

ABORt

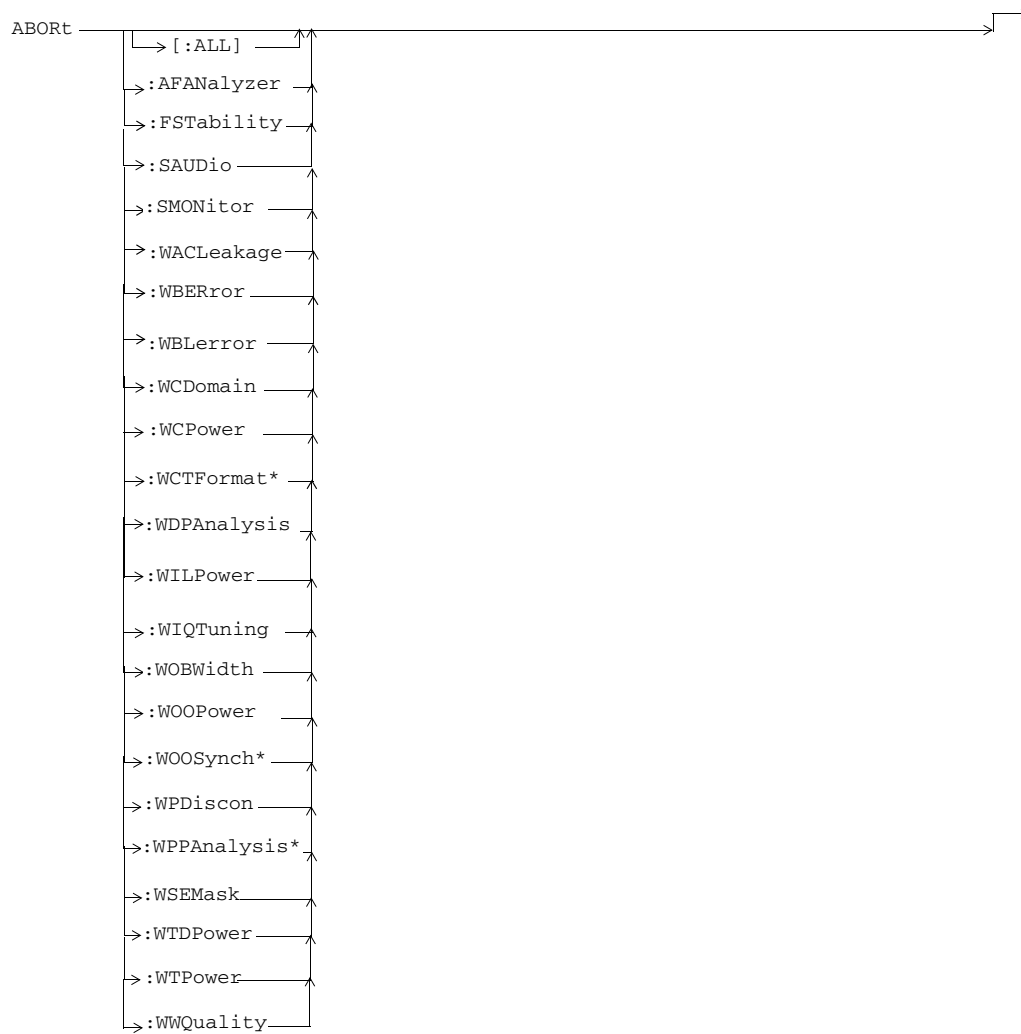

* This command is only applicable to the lab application.

AFGenerator

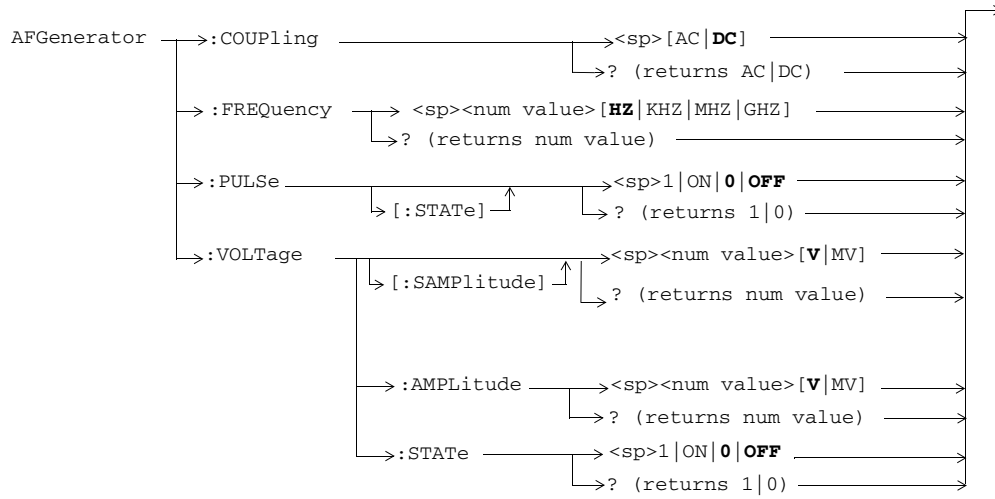

GPIB Syntax for E1963A and E6703C

CALCulate:SMONitor

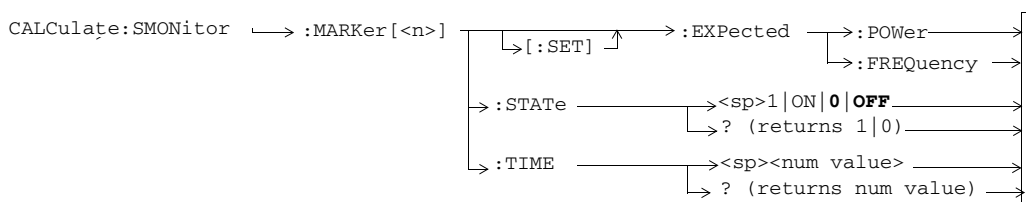
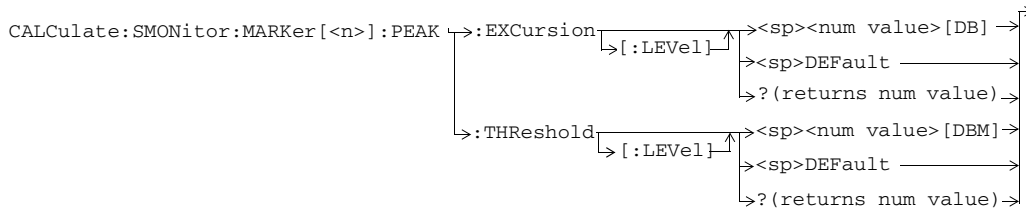
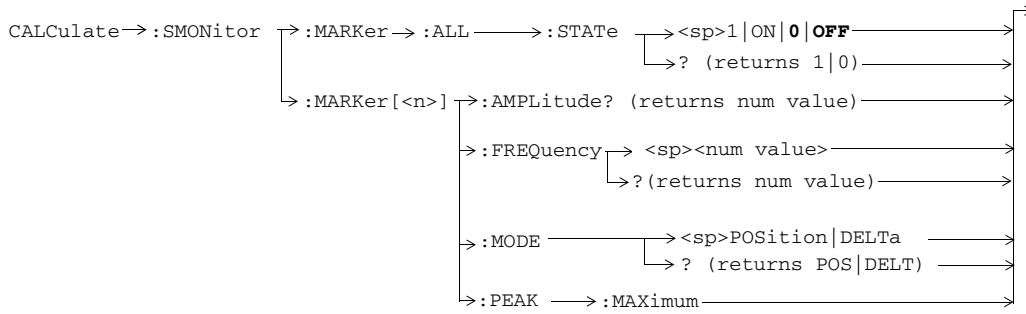

CALibration

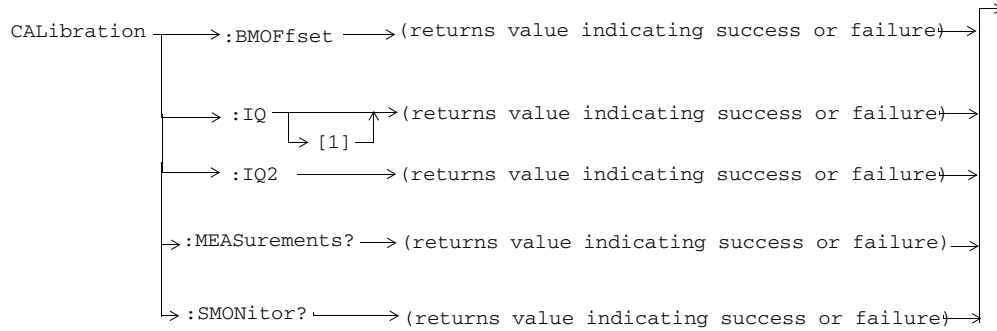

CALL:AICHannel

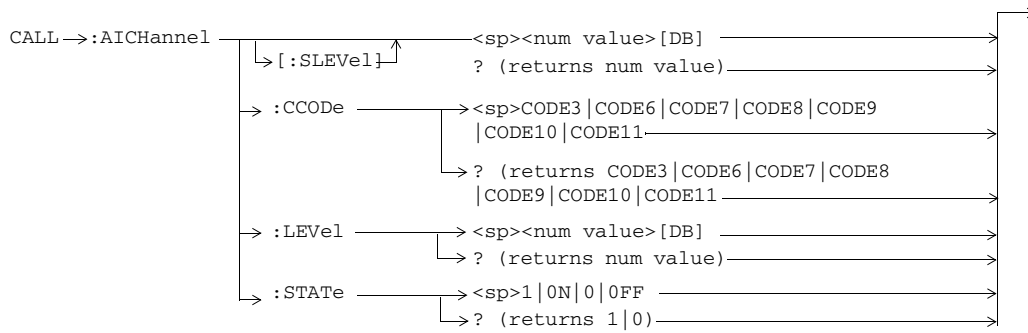

CALL:ATTFlag

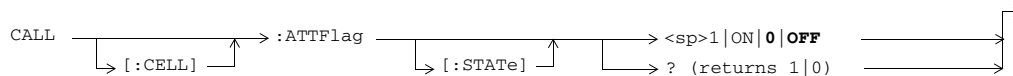

GPIO Syntax for E1963A and E6703C

CALL:AWGNoise

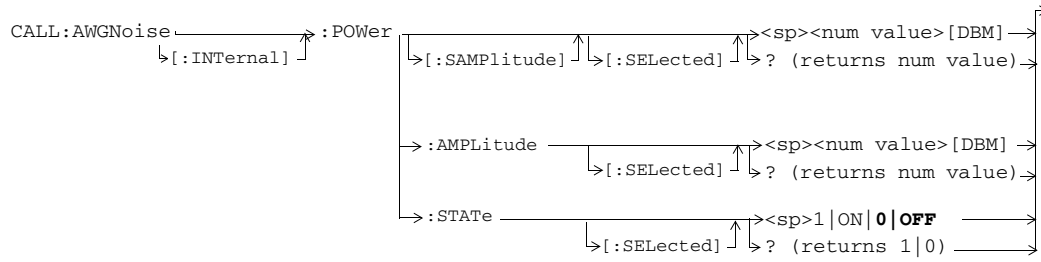

CALL:BCCHannel

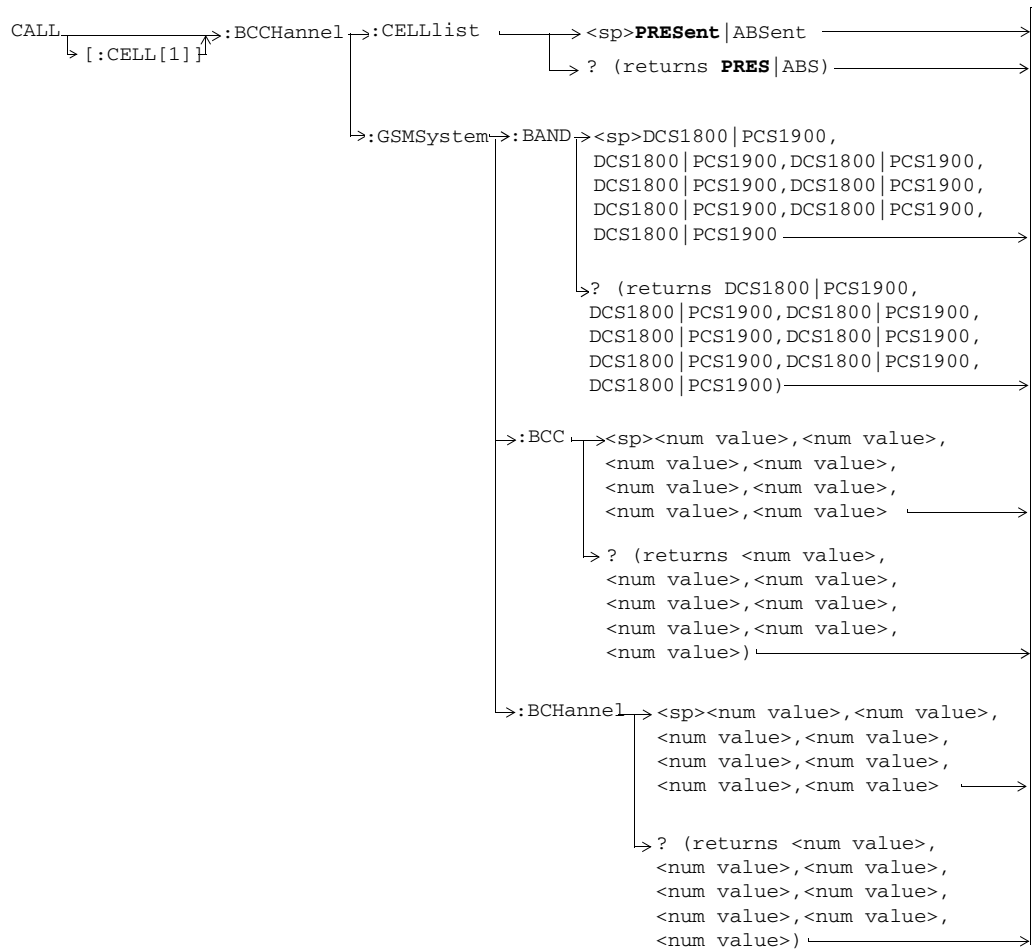

GPiB Syntax for E1963A and E6703C

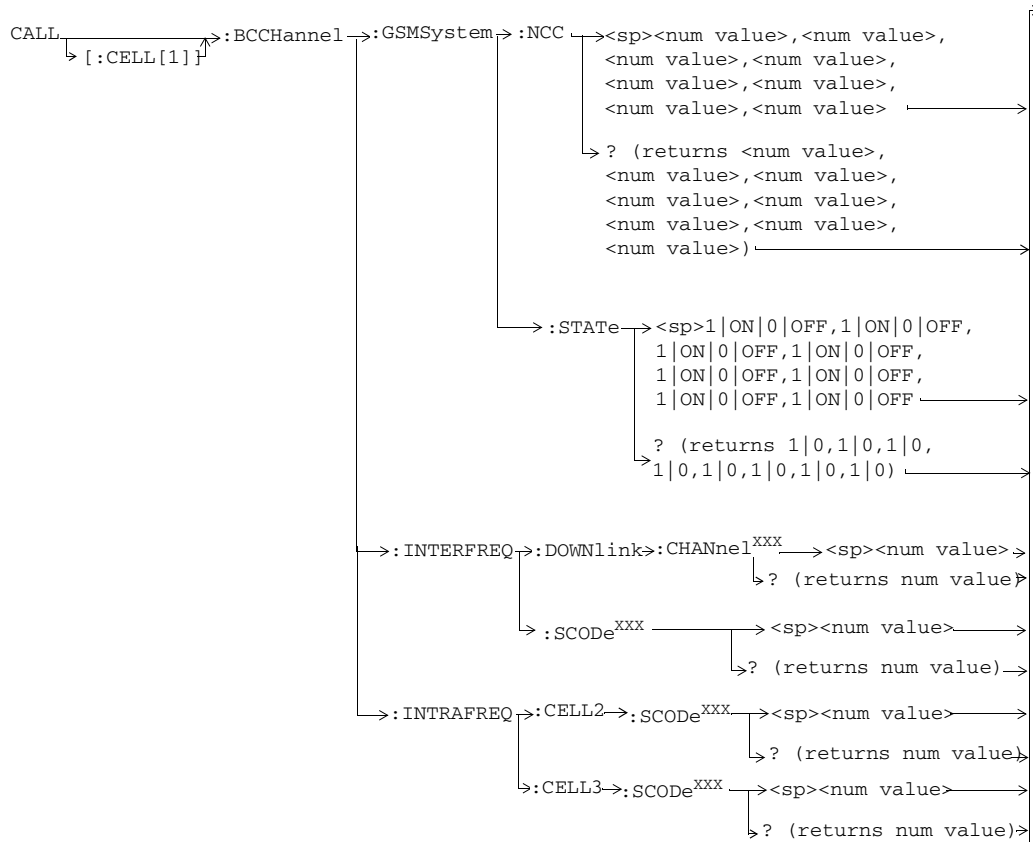

^{xxx} This command is obsolete.

GPIB Syntax for E1963A and E6703C

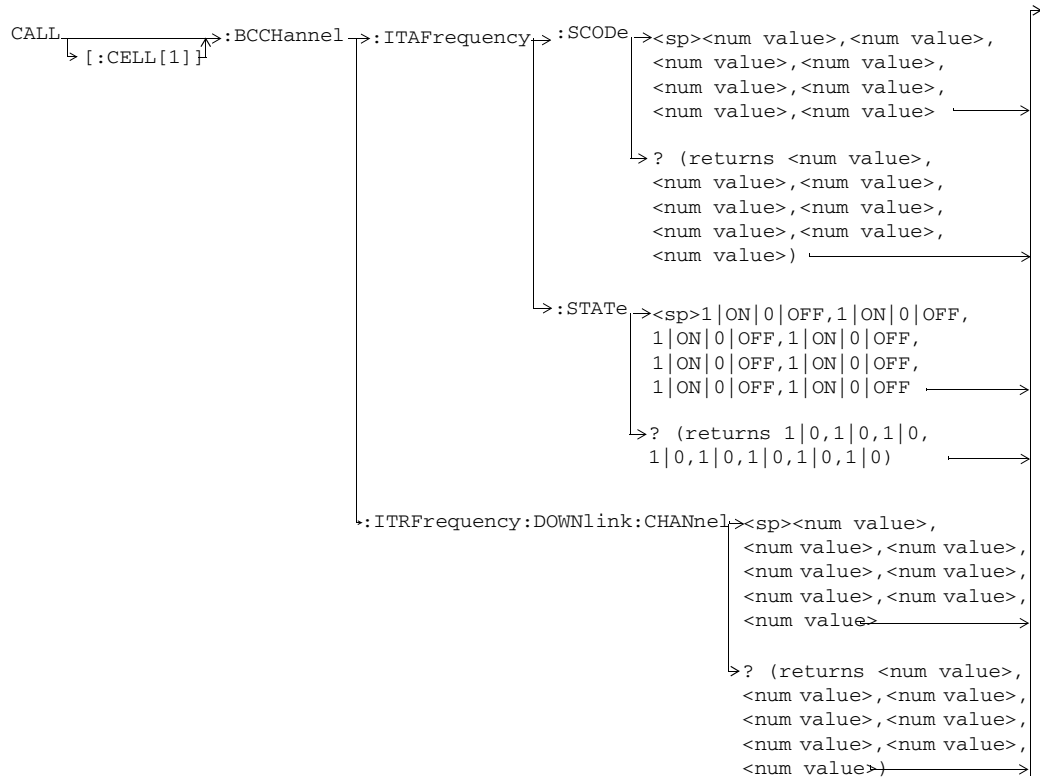

GPiB Syntax for E1963A and E6703C

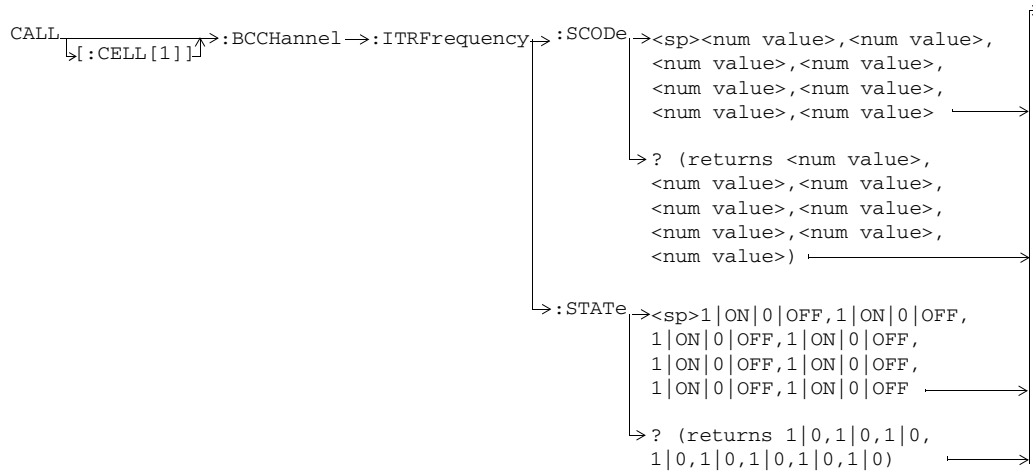

GPiB Syntax for E1963A and E6703C



* This command is only applicable to the lab application.

GPiB Syntax for E1963A and E6703C

CALL:CCPChannel

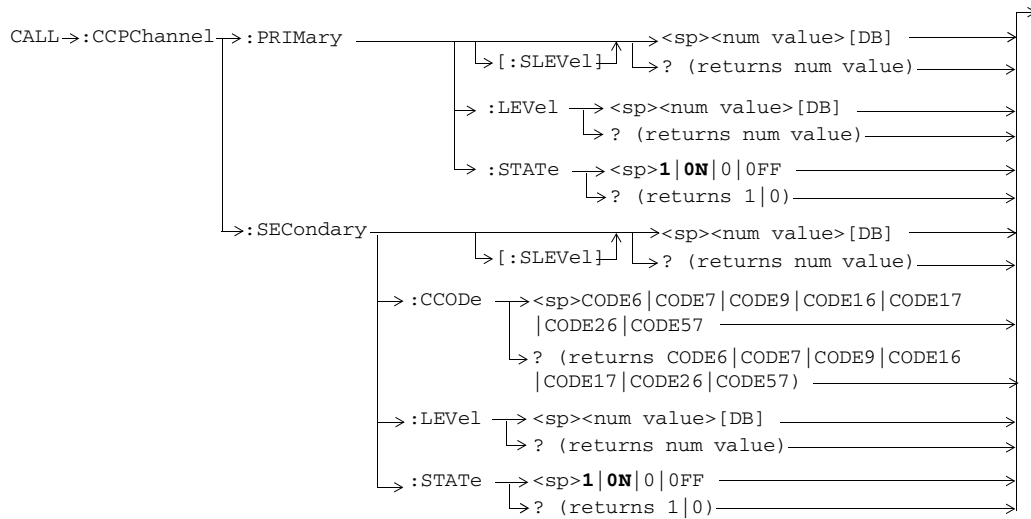

CALL:CELL2:CCPChannel

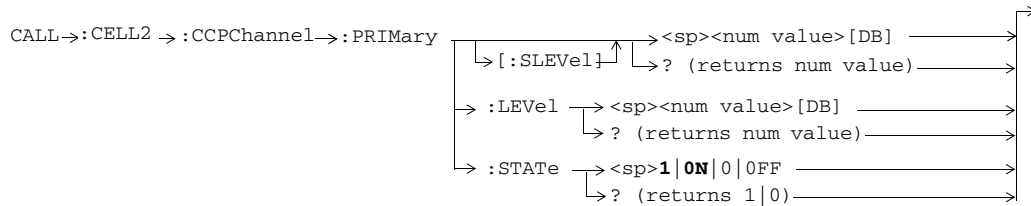

All commands shown in this diagram are only applicable to the lab application.

CALL:CELL2:CLPControl

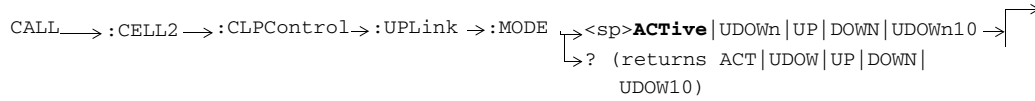

All commands shown in this diagram are only applicable to the lab application.

CALL:CELL2:CPICchannel

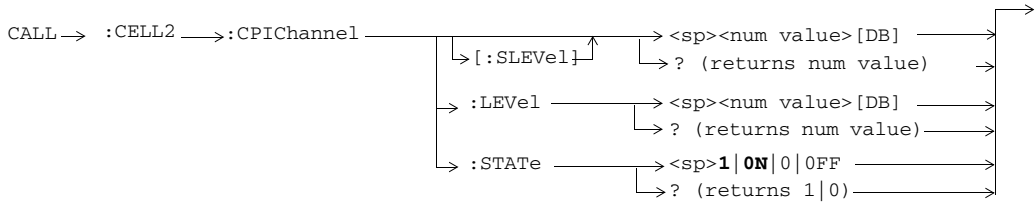

All commands shown in this diagram are only applicable to the lab application.

CALL:CELL2:DPCHannel

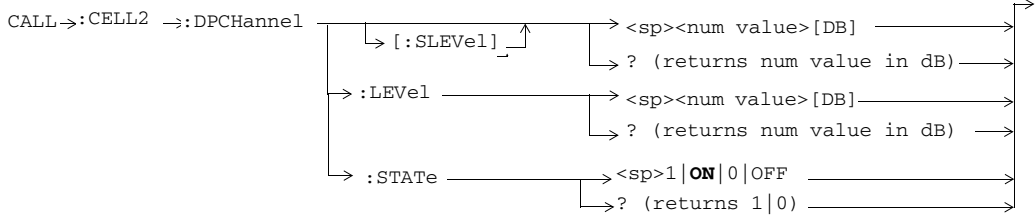

All commands shown in this diagram are only applicable to the lab application.

CALL:CELL2:OCNSource

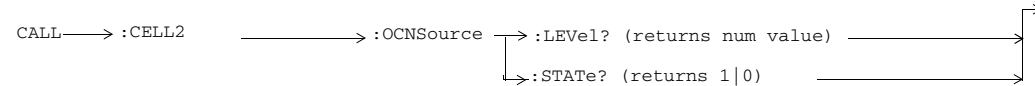

All commands shown in this diagram are only applicable to the lab application.

GPiB Syntax for E1963A and E6703C

CALL:CELL2:POWer

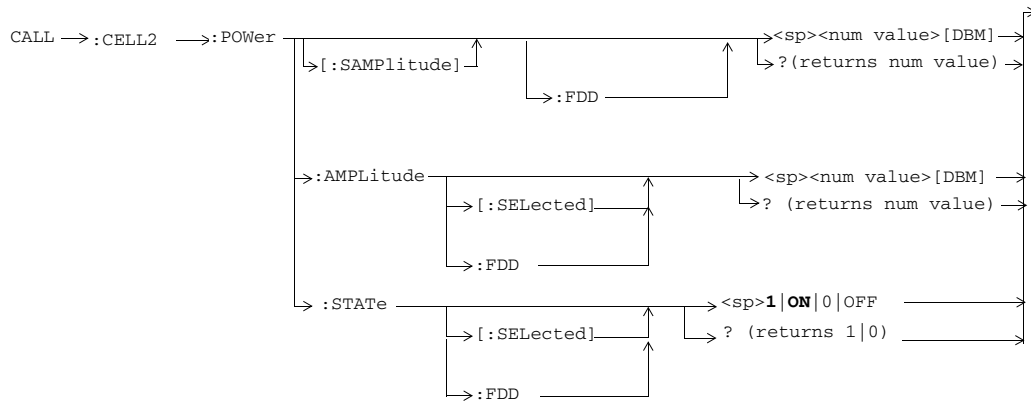

All commands shown in this diagram are only applicable to the lab application.

CALL:CELL2:SCODE

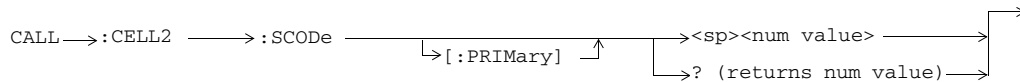

All commands shown in this diagram are only applicable to the lab application.

CALL:CELL2:TOFFset

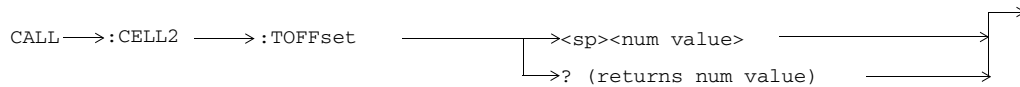

All commands shown in this diagram are only applicable to the lab application.

CALL:CHANnel

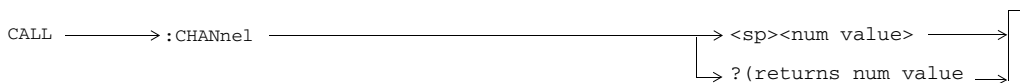

CALL:CLPControl

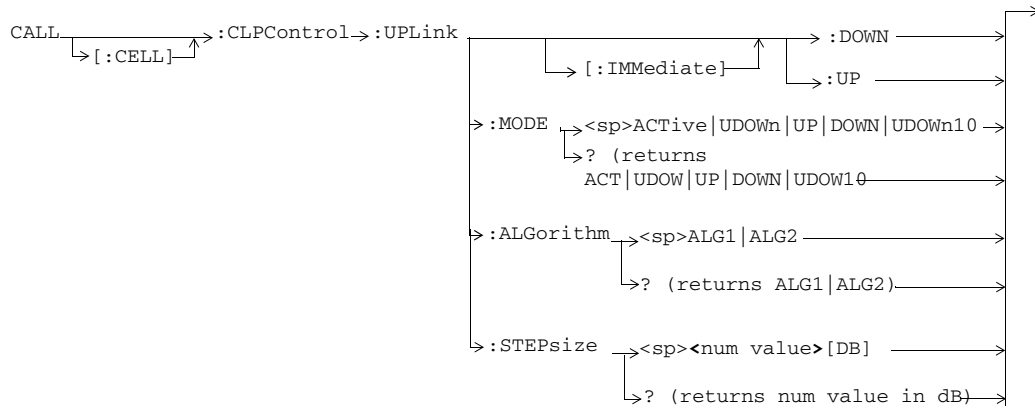

GPIO Syntax for E1963A and E6703C

CALL:COMPRESSED

This section is only applicable to the lab application.

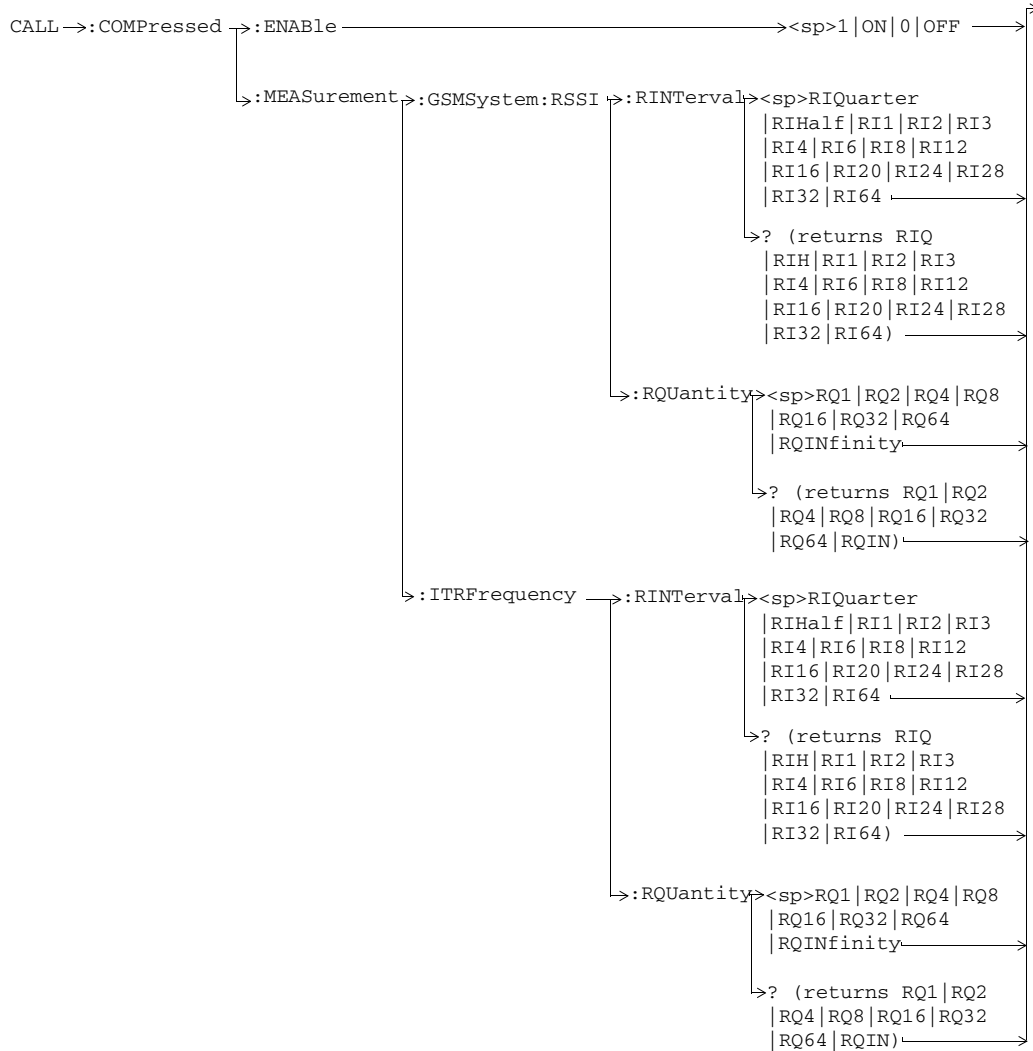

GPIB Syntax for E1963A and E6703C

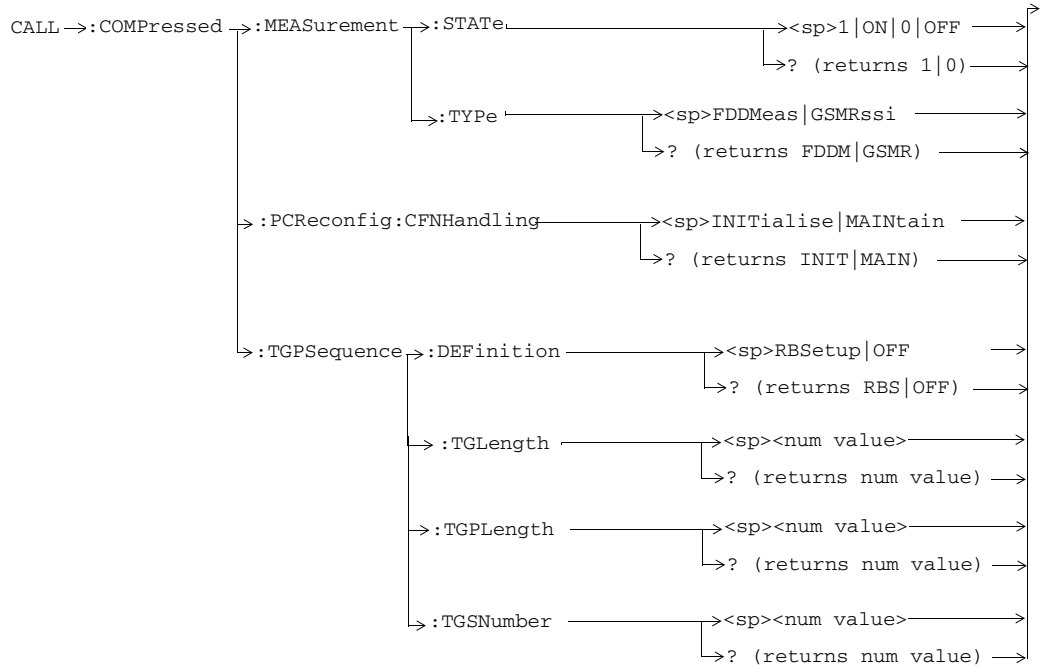

GPiB Syntax for E1963A and E6703C

CALL:CONNECTed

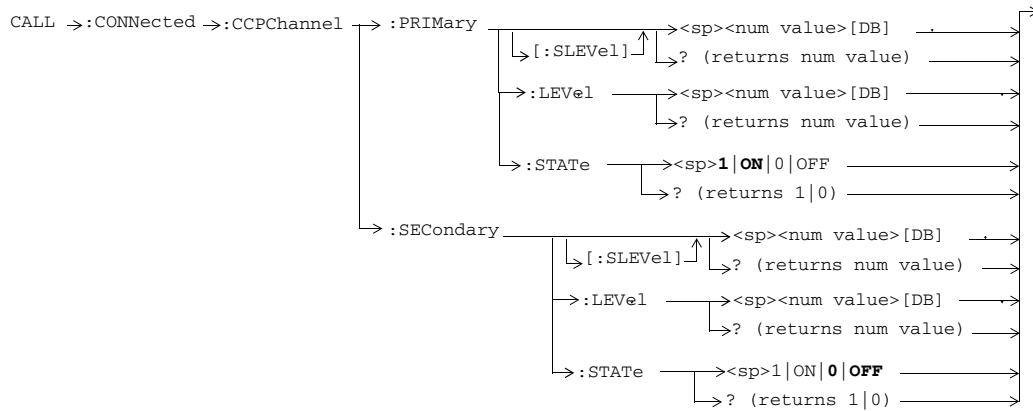
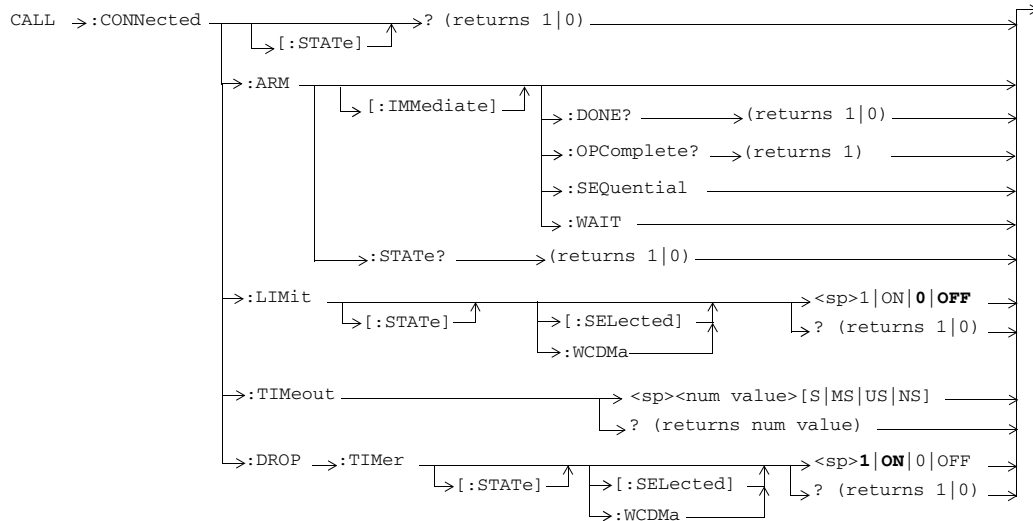

GPIO Syntax for E1963A and E6703C

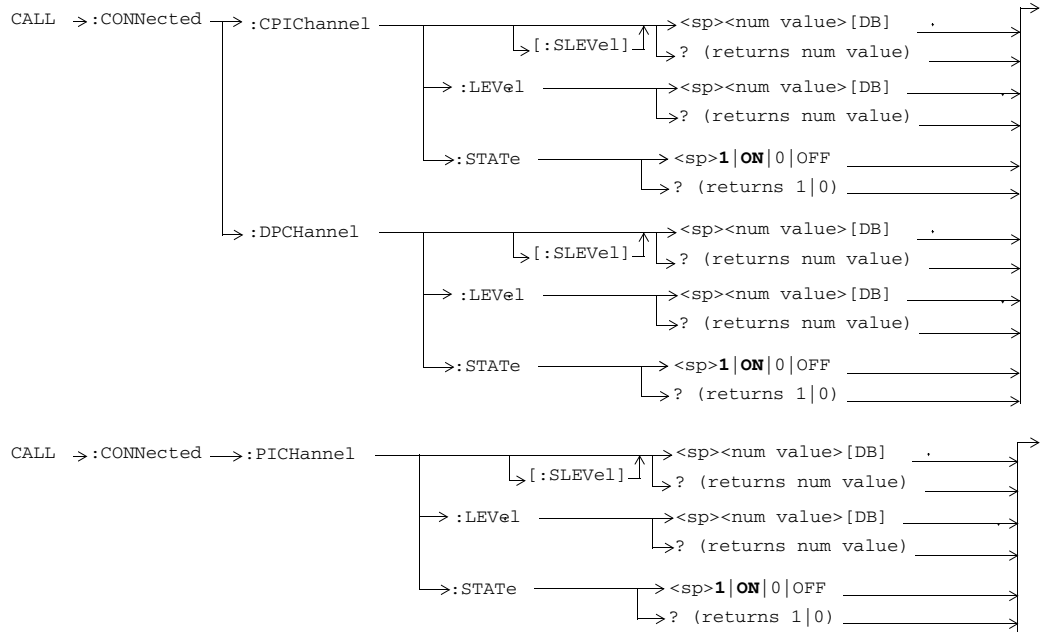

GPiB Syntax for E1963A and E6703C

CALL:CONTRol

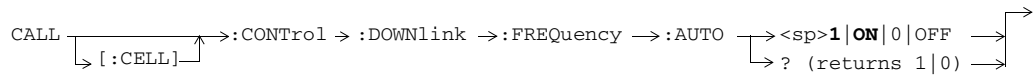

CALL:COUNT

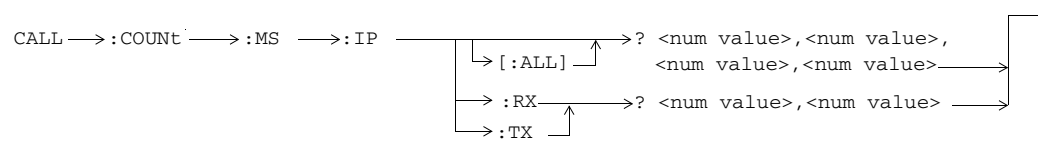

All commands shown in this diagram are only applicable to the lab application.

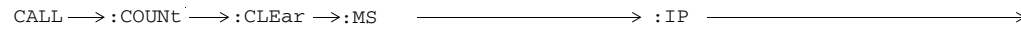

All commands shown in this diagram are only applicable to the lab application.

CALL:COUNT:DTMonitor

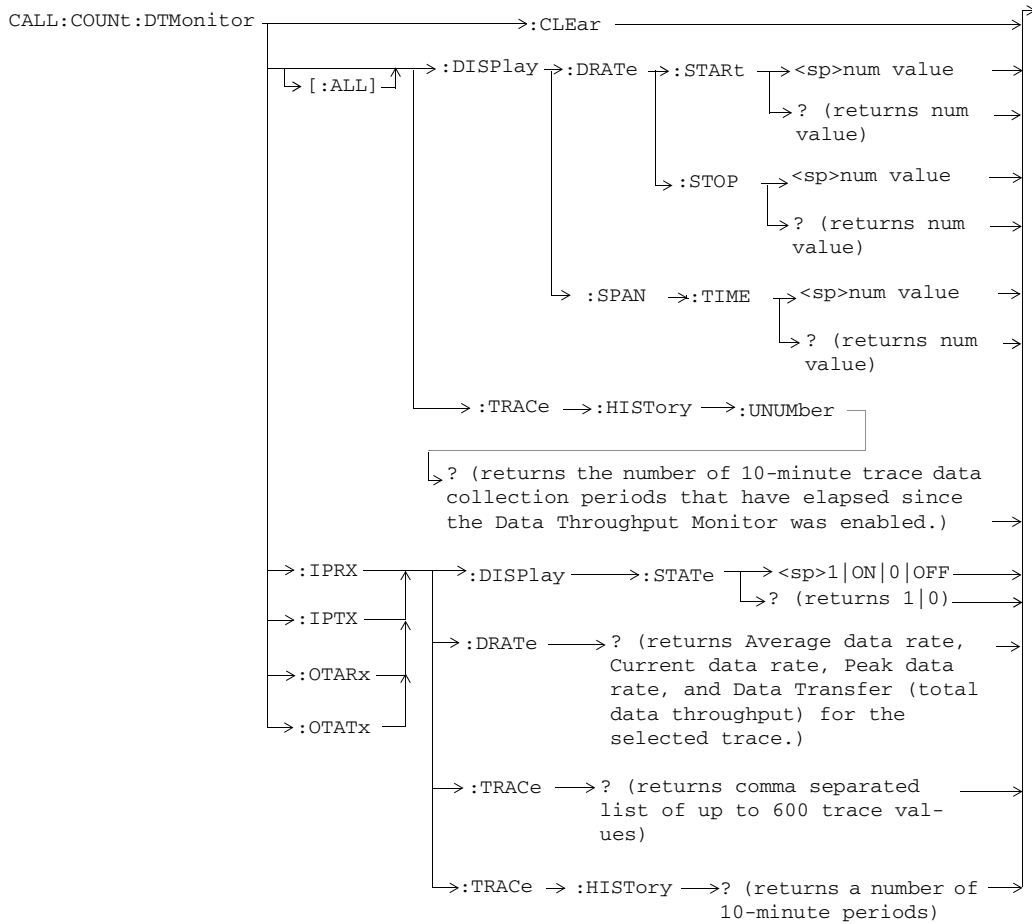

All commands shown in this diagram are only applicable to the lab application.

GPiB Syntax for E1963A and E6703C

CALL:CPiChannel

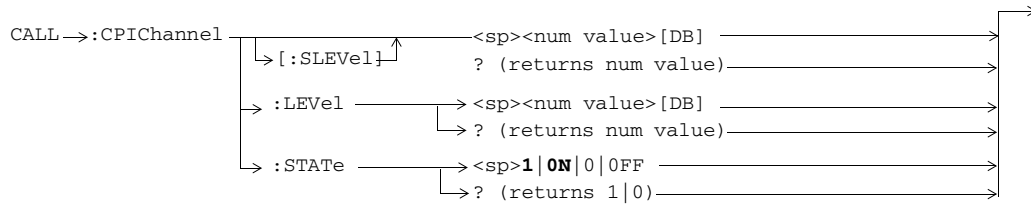

CALL:CPNumber

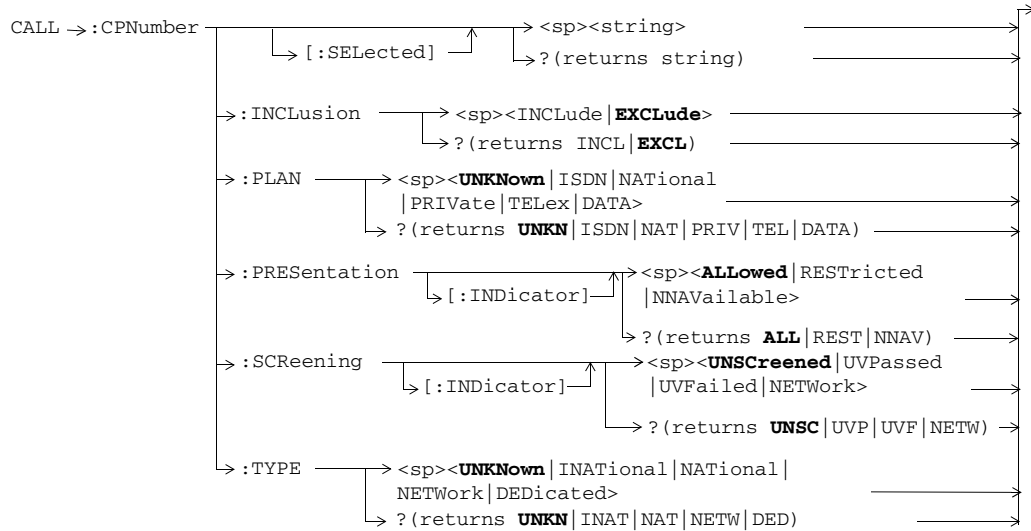

These commands are only applicable to the lab application.

CALL:CVALue

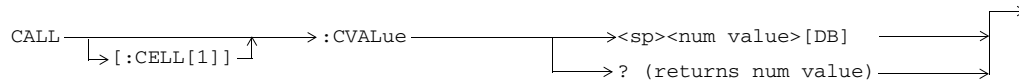

CALL:DATA:PING

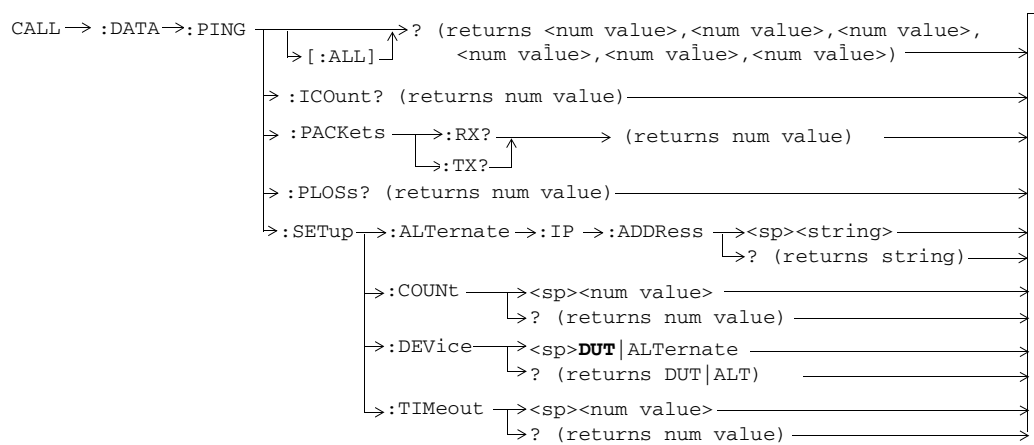

All commands shown in this diagram are only applicable to the lab application.

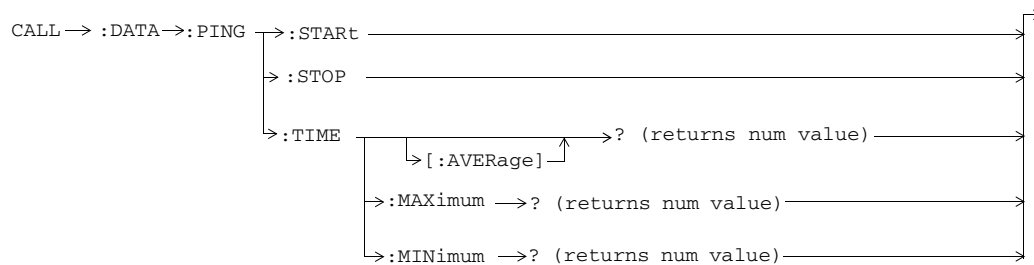

All commands shown in this diagram are only applicable to the lab application.

GPiB Syntax for E1963A and E6703C

CALL:DPCHannel

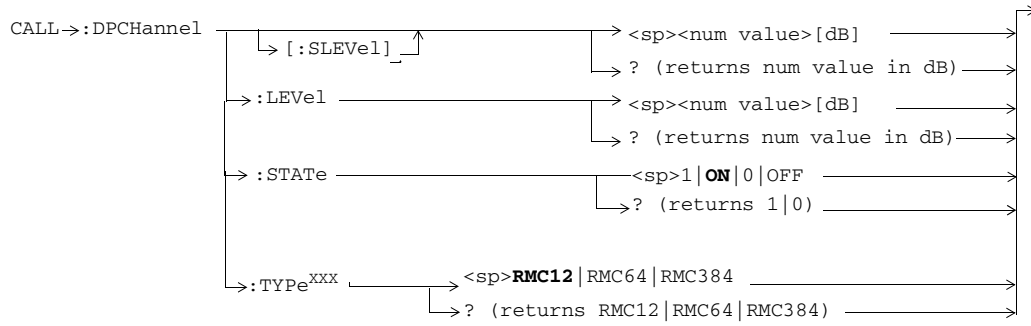

XXX This command is obsolete.

GPIB Syntax for E1963A and E6703C

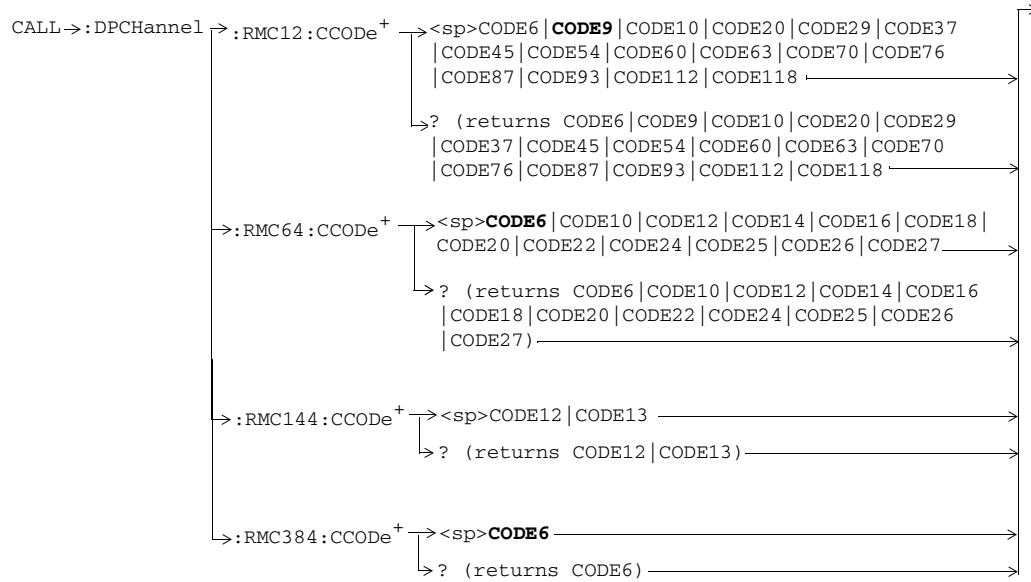

⁺ This command is only applicable to the test application.

GPiB Syntax for E1963A and E6703C

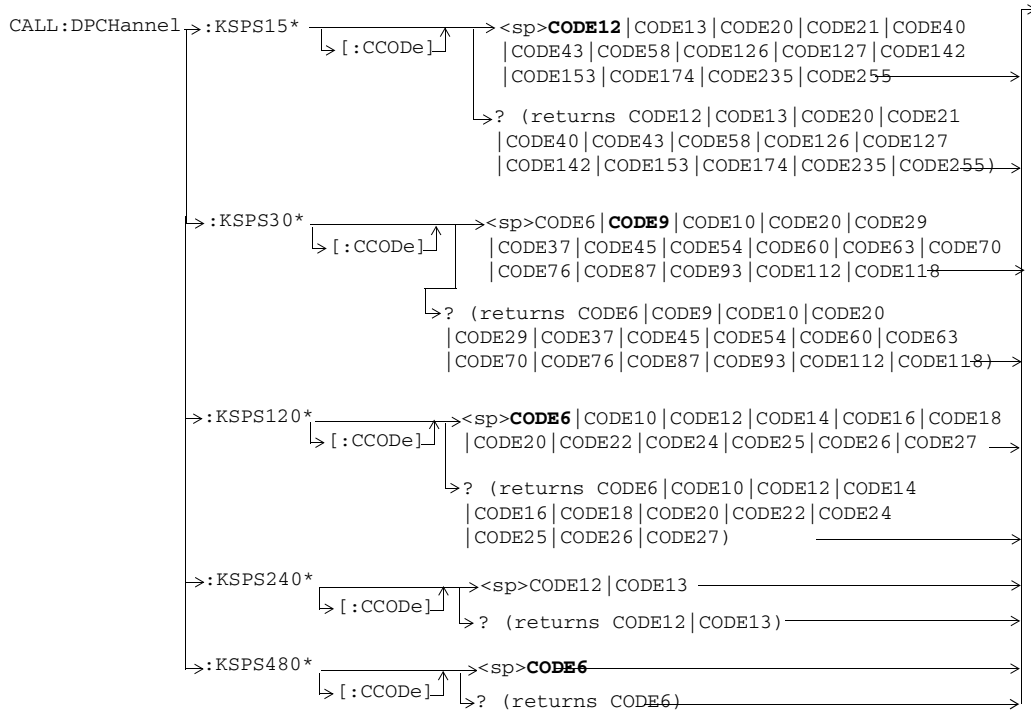

* This command is only applicable to the lab application.

CALL:END

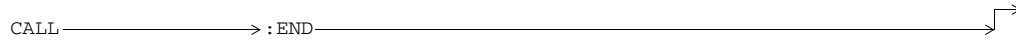

GPIO Syntax for E1963A and E6703C

CALL:FDDTest



* This command is only applicable to the lab application.

GPIB Syntax for E1963A and E6703C

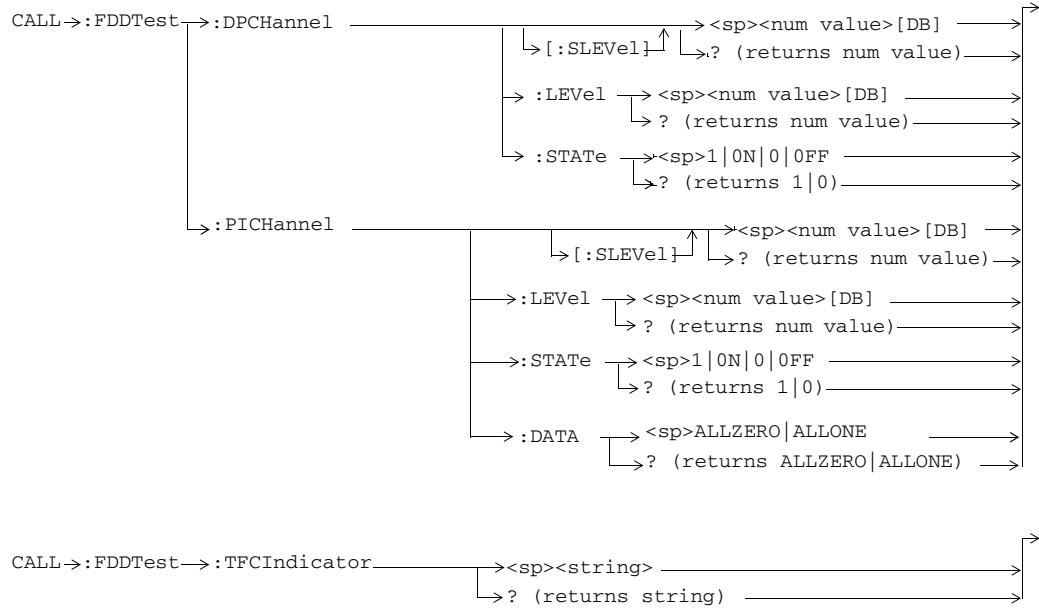

GPiB Syntax for E1963A and E6703C

CALL:HANdoff

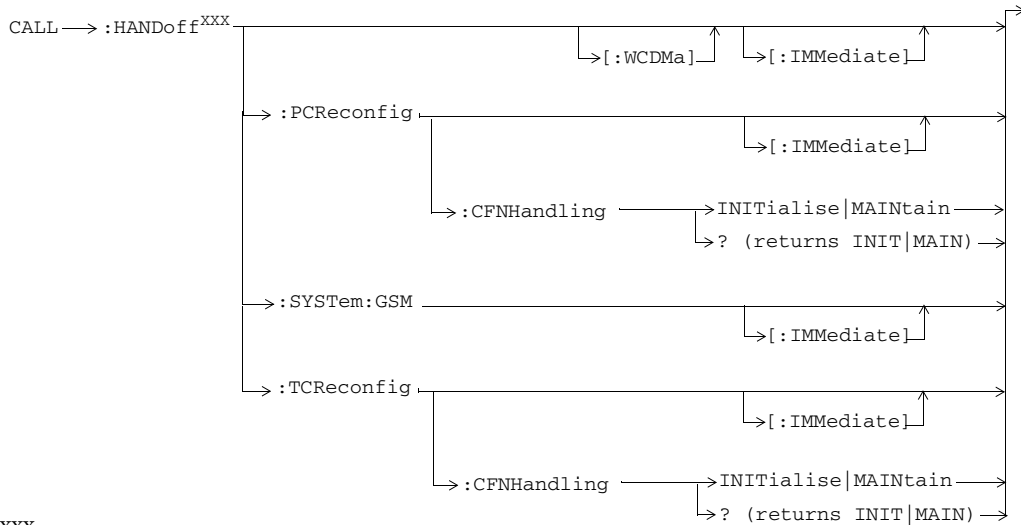

XXX This command is obsolete.

CALL:IDENtity

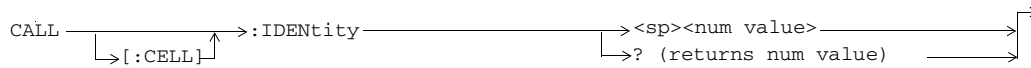

CALL:LACode

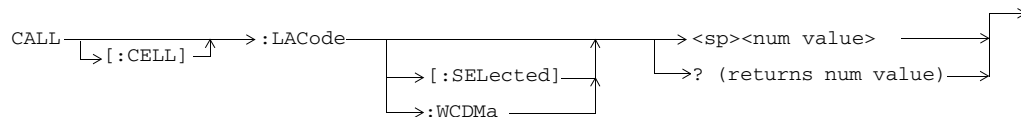

CALL:MNCcode

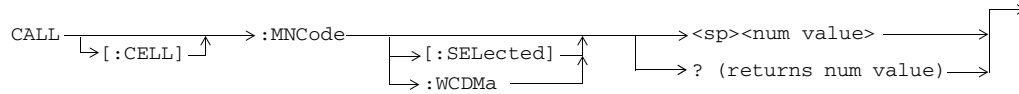

CALL:MS:IP:ADDRESS

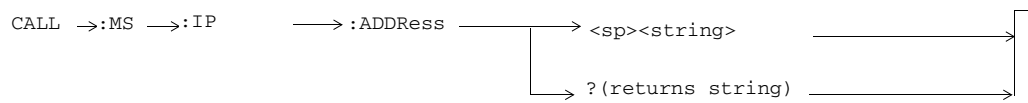

All commands shown in this diagram are only applicable to the lab application.

CALL:MS:LOOPback

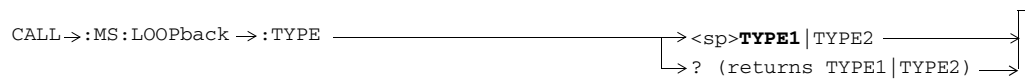

CALL:MS:POWER

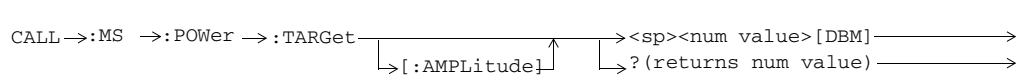

CALL:MS:REPorted



* This query is only applicable to the lab application.

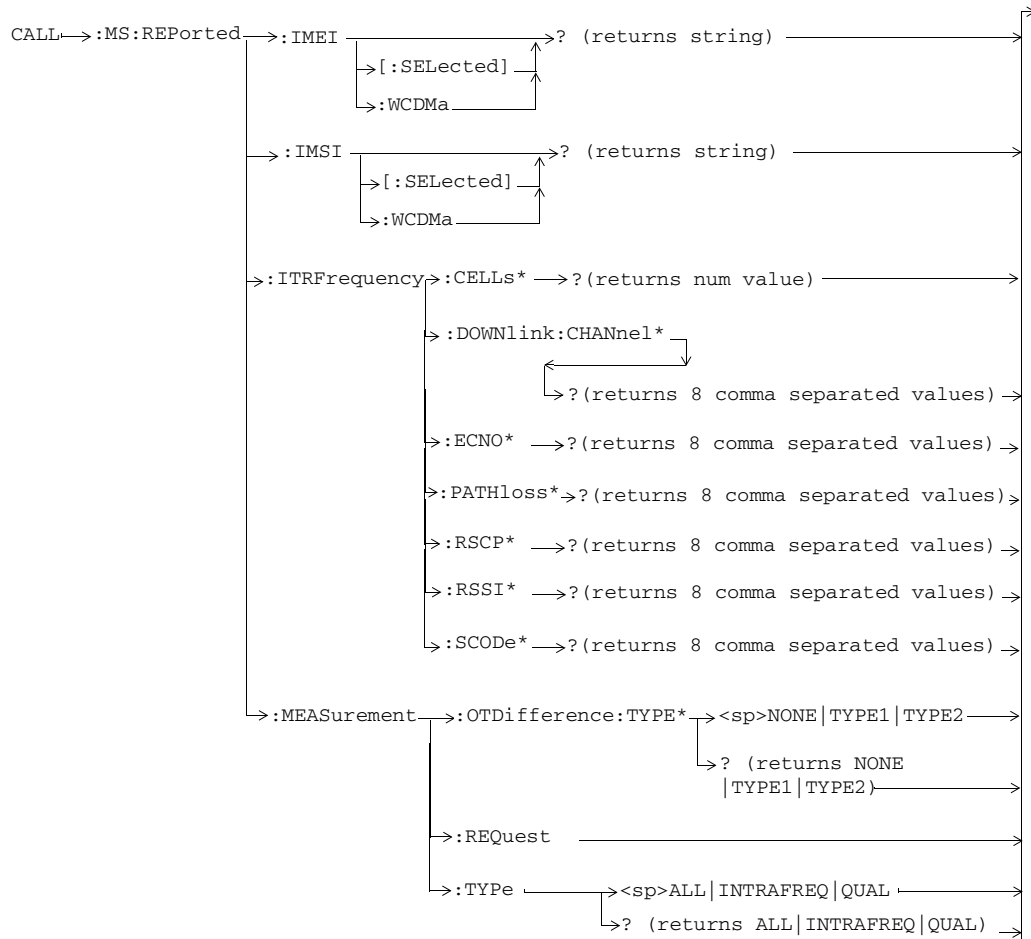

* This command is only applicable to the lab application.

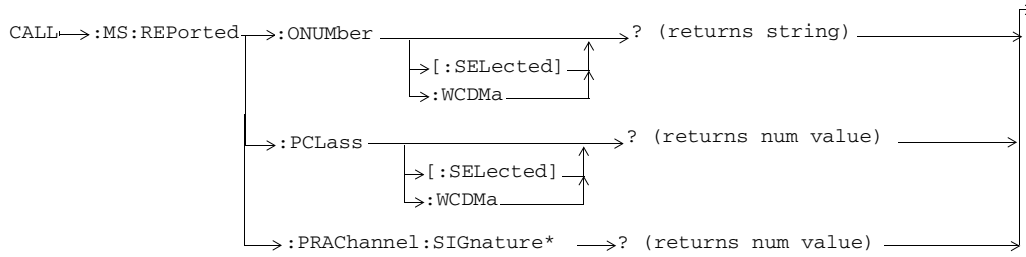

* This command is only applicable to the lab application.

CALL:OCNSource

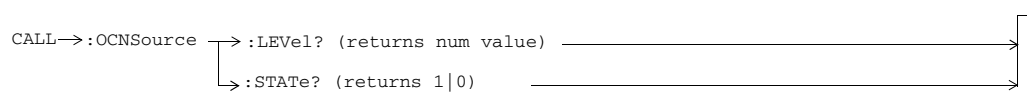

CALL:OPERating

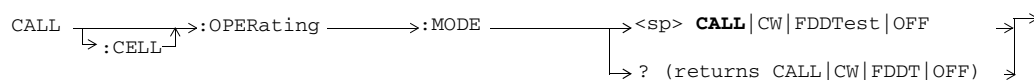

CALL:ORIGinate

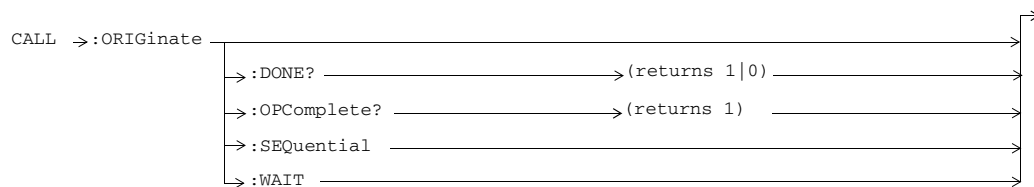

CALL:PAGing

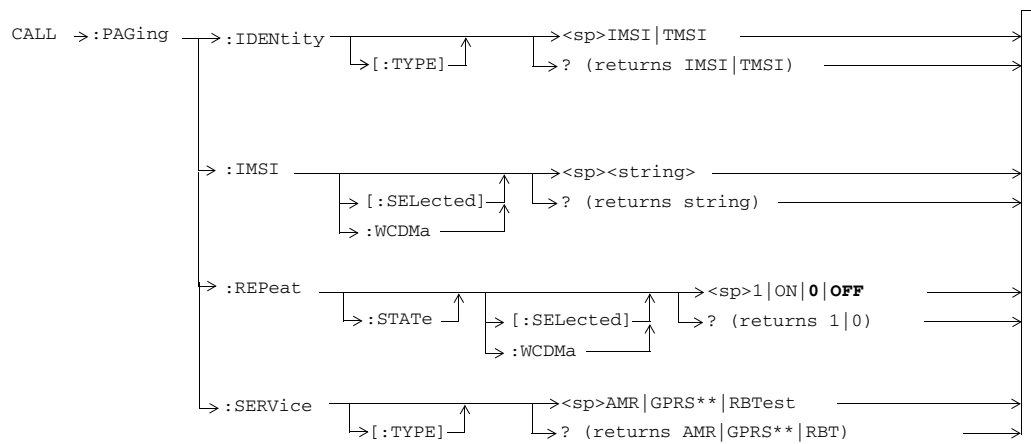

** This setting/query return is only applicable to the lab application.

CALL:PCTPower

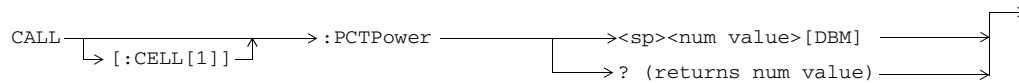

CALL:PIChannel

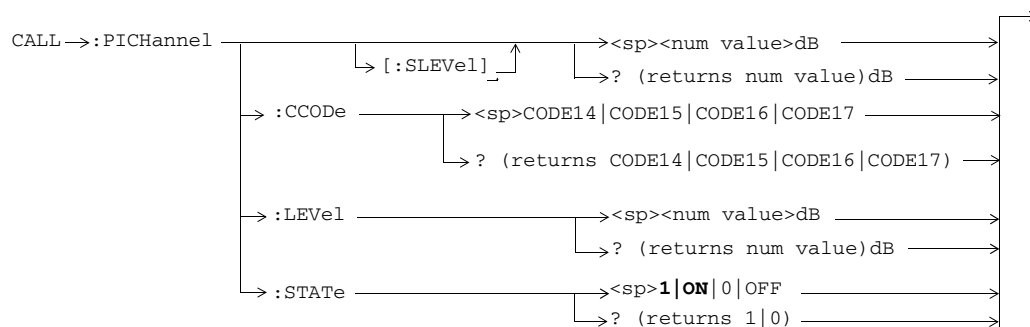

CALL:PLOGging

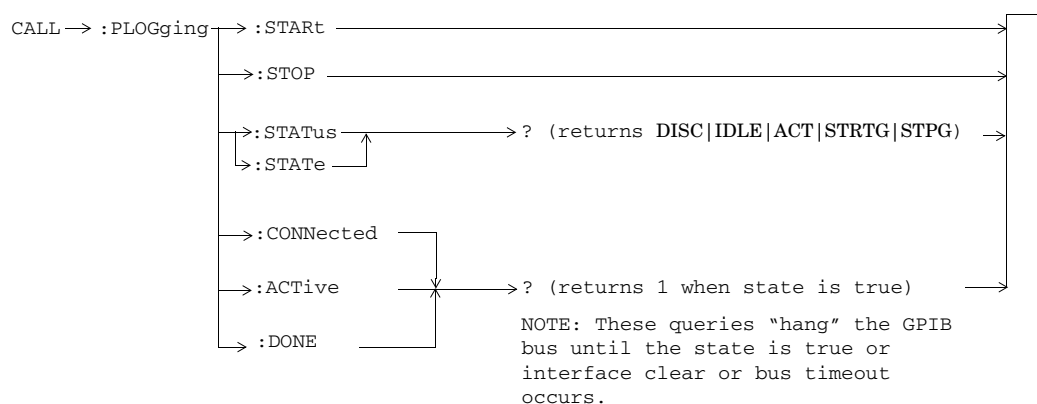

All commands shown in this diagram are only applicable to the lab application.

CALL:POWer

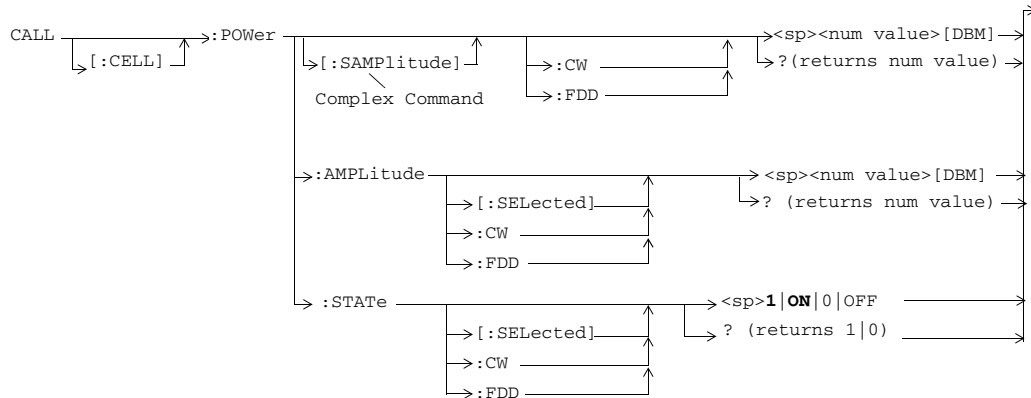

CALL:PSDomain

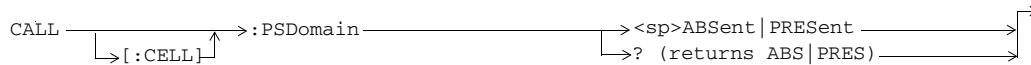

CALL:RACode

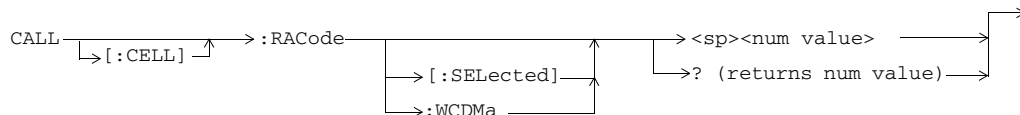

CALL:RBSetup

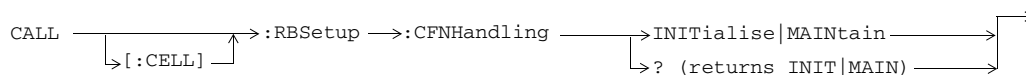

CALL:RFGenerator

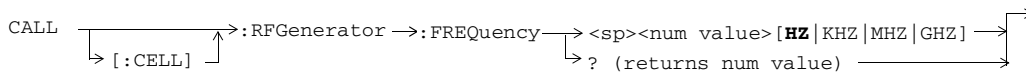

CALL:RLC

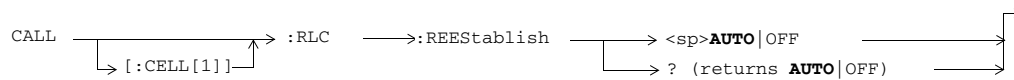

CALL:SCODE

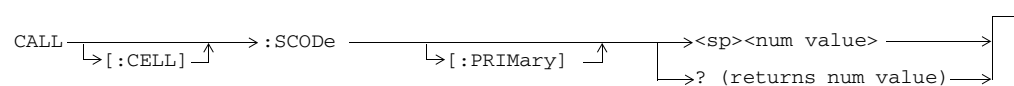

CALL:SECurity

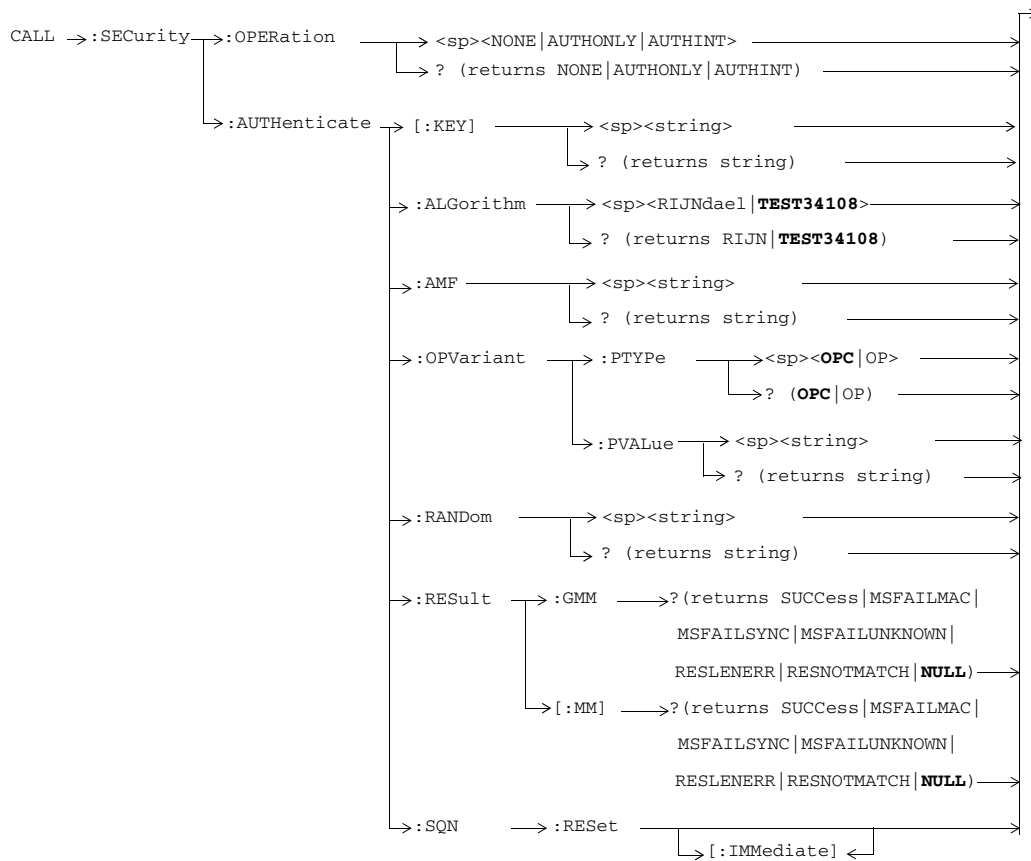

CALL:SERvice

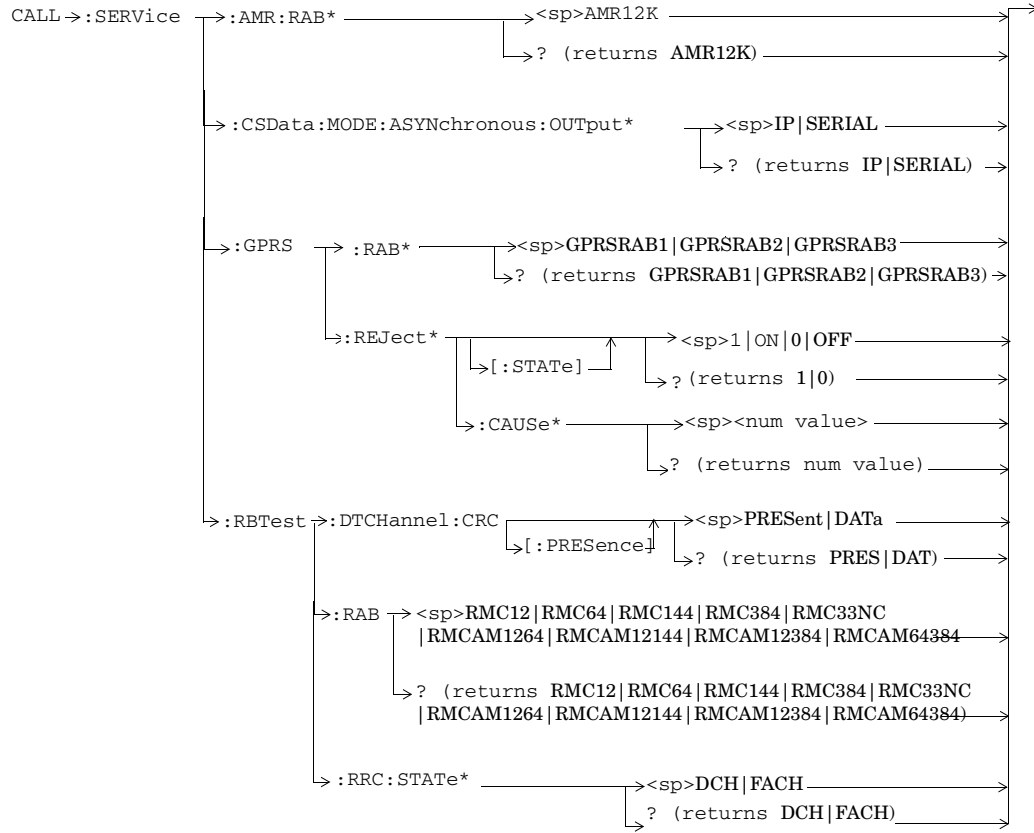

* This command is only applicable to the lab application.

CALL:SETup

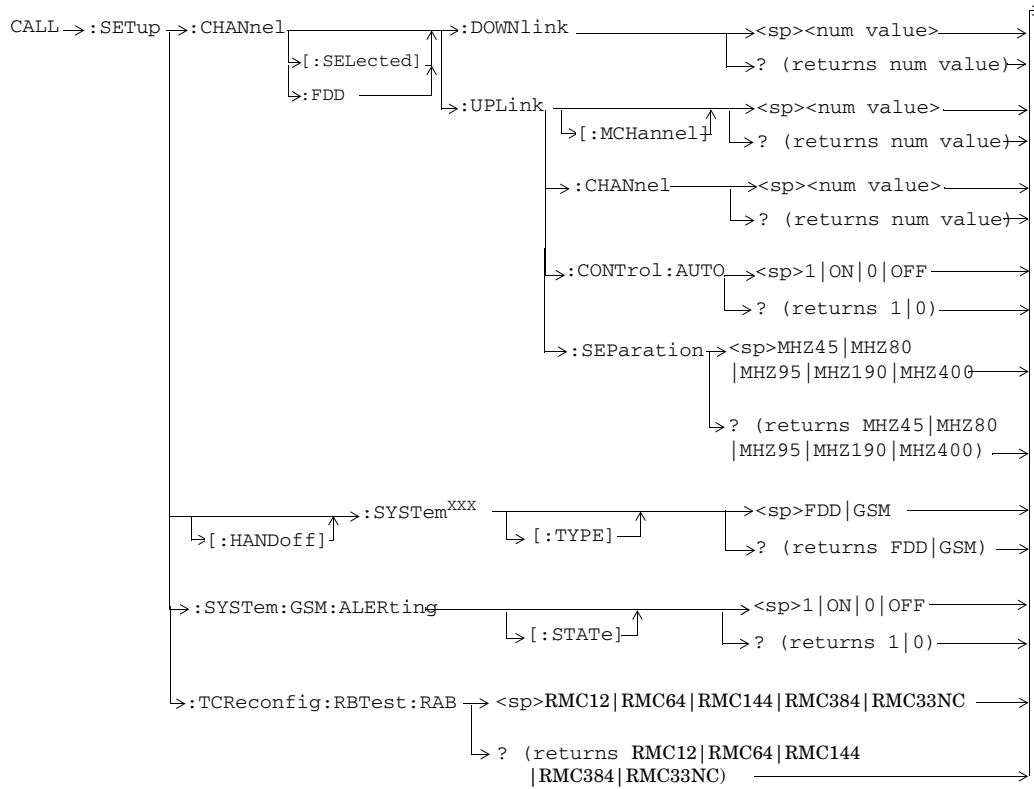

^{xxx} This command is obsolete.

CALL:SHANdoff

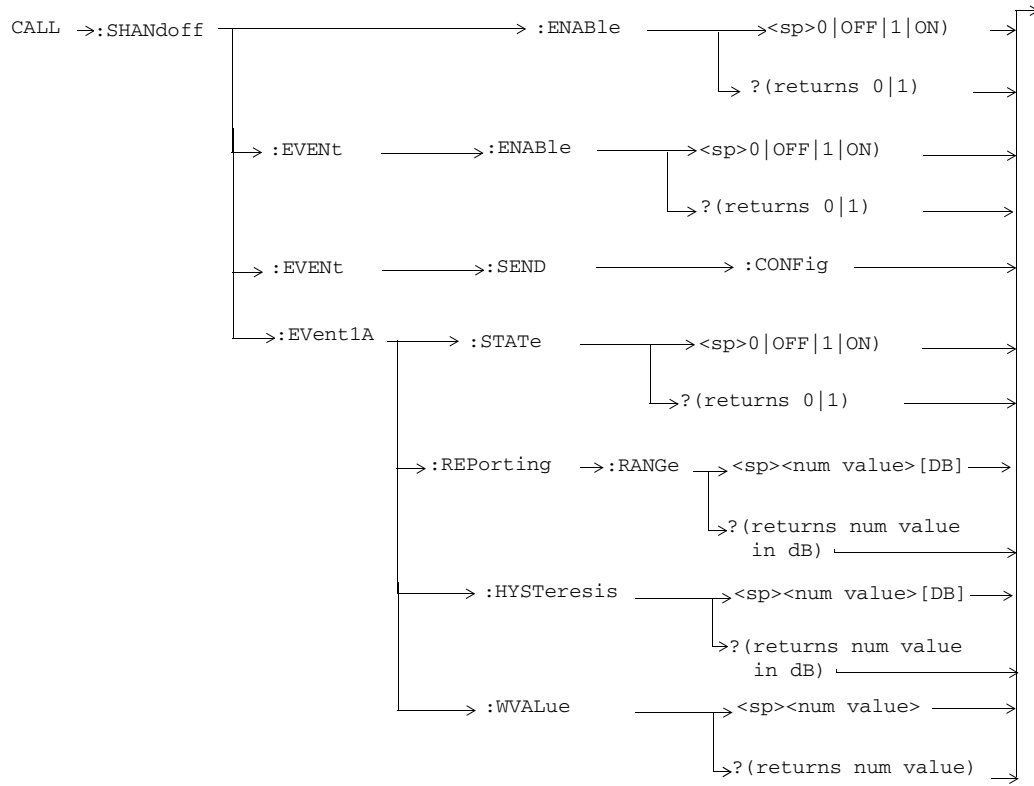

All commands shown in this diagram are only applicable to the lab application.

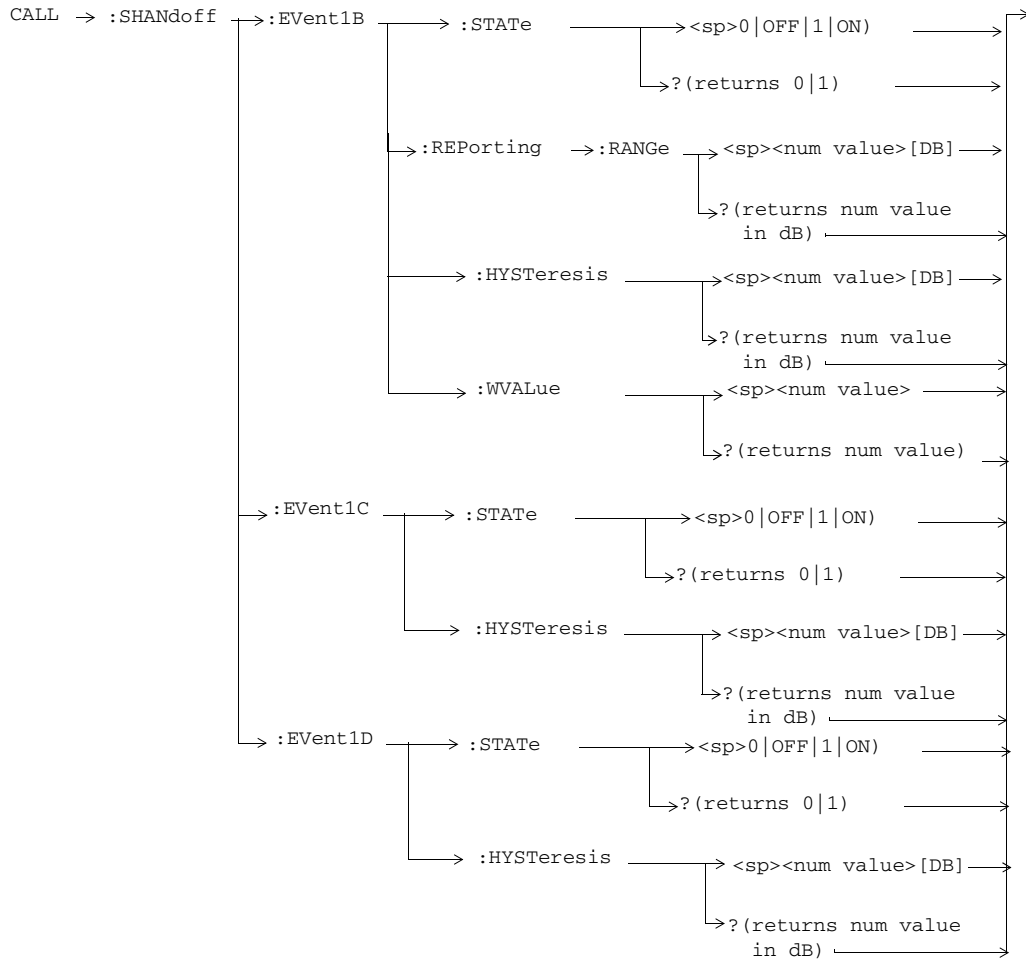

All commands shown in this diagram are only applicable to the lab application.

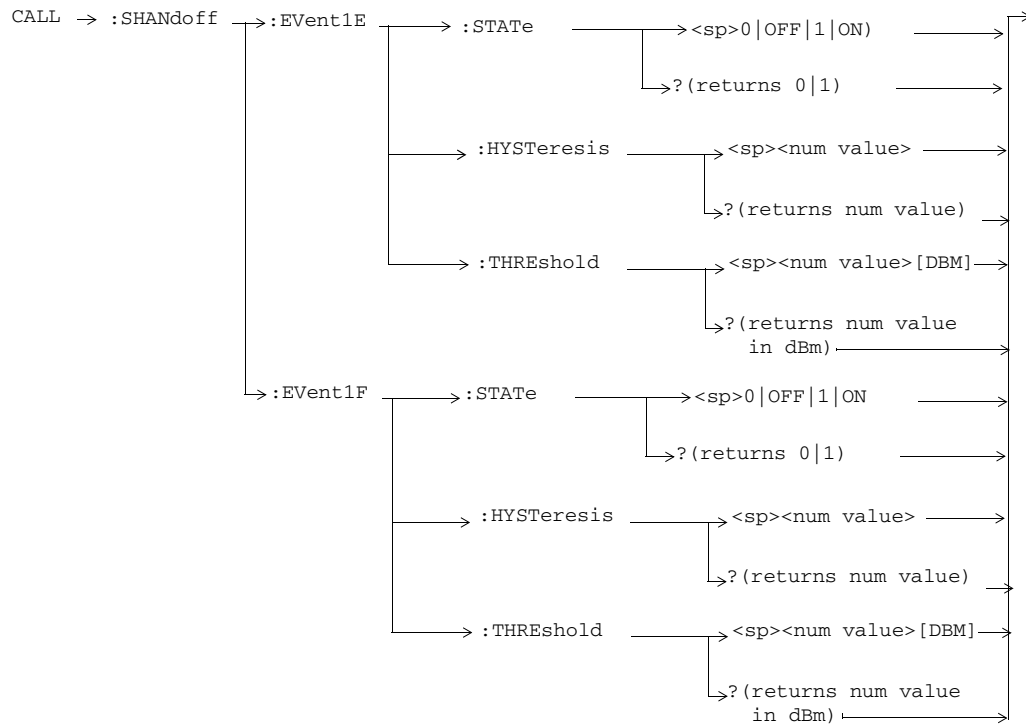

All commands shown in this diagram are only applicable to the lab application.

CALL:SMSservice

This section is only applicable to the lab application.

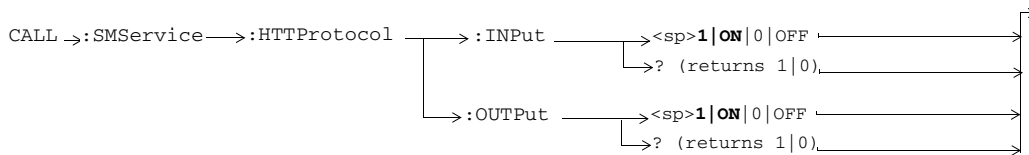
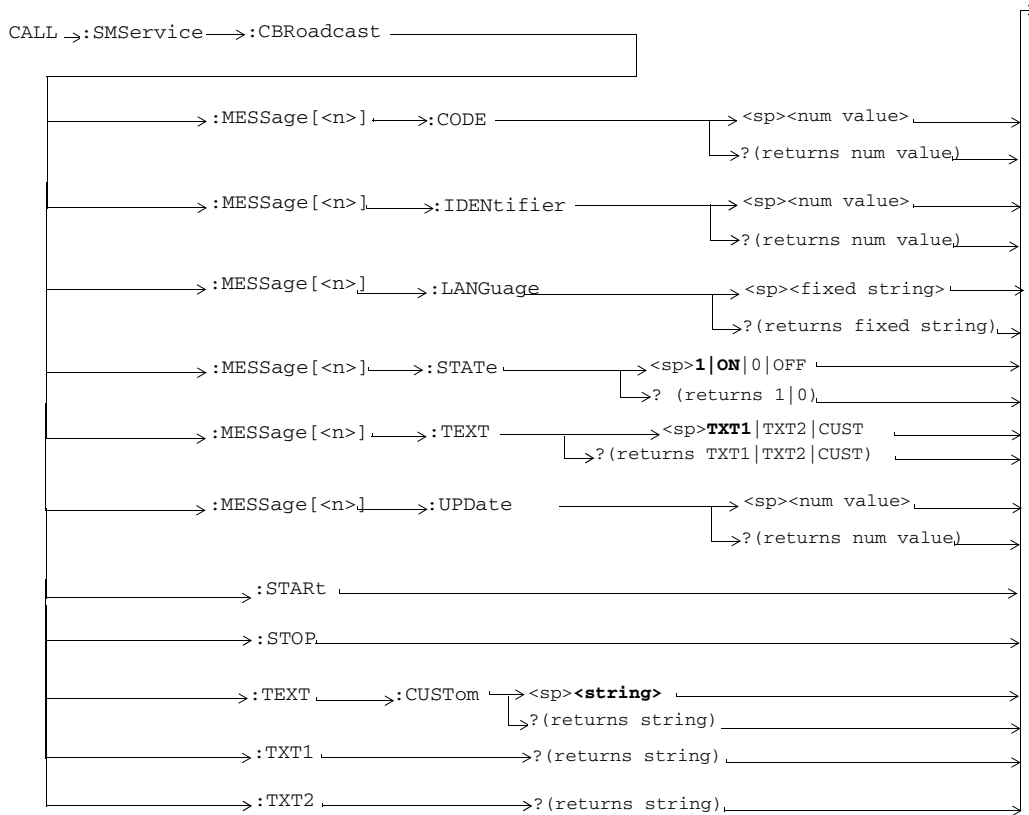



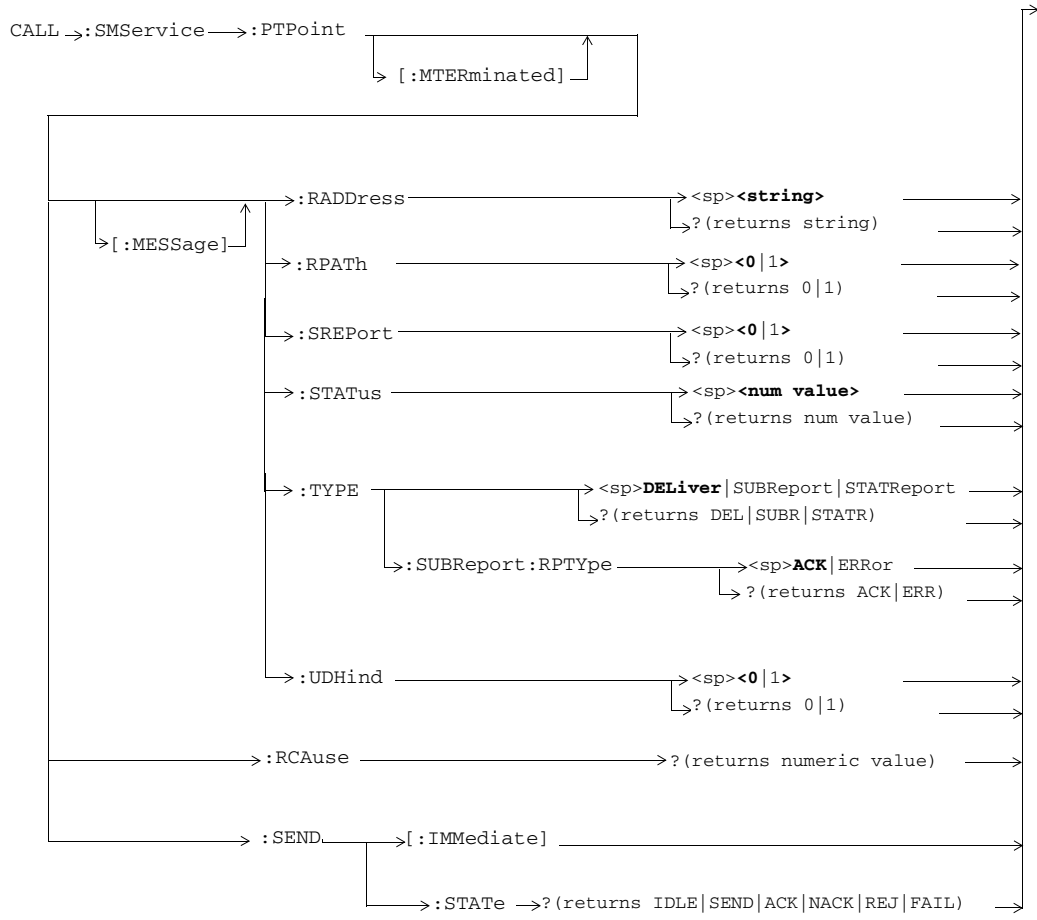

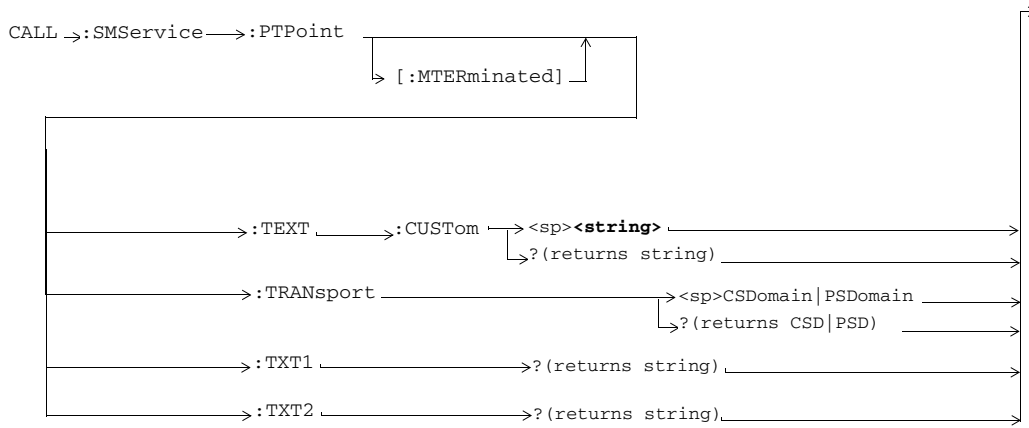

CALL:SRBearer

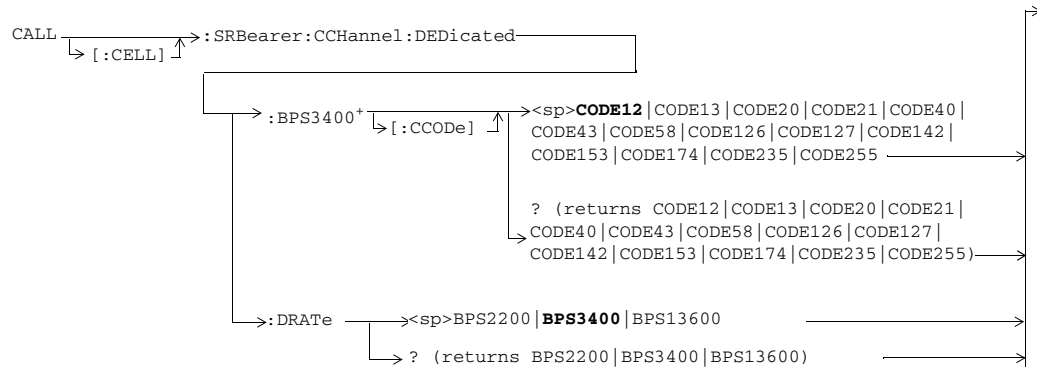

+ This command is only applicable to the test application.

CALL:STATUs

NOTE The CALL:STATUs commands are query only. They return values that indicate the test set's actual hardware settings. Actual hardware settings can differ from settings the user has entered, most frequently due to an error condition. When no error conditions exist, the commands used to enter values will return the same results as the commands used to query actual hardware settings. For example, "CALL:AWGNoise:POWer?" will return the same value as "CALL:STATUs:AWGNoise:POWer?" when no error conditions exist.

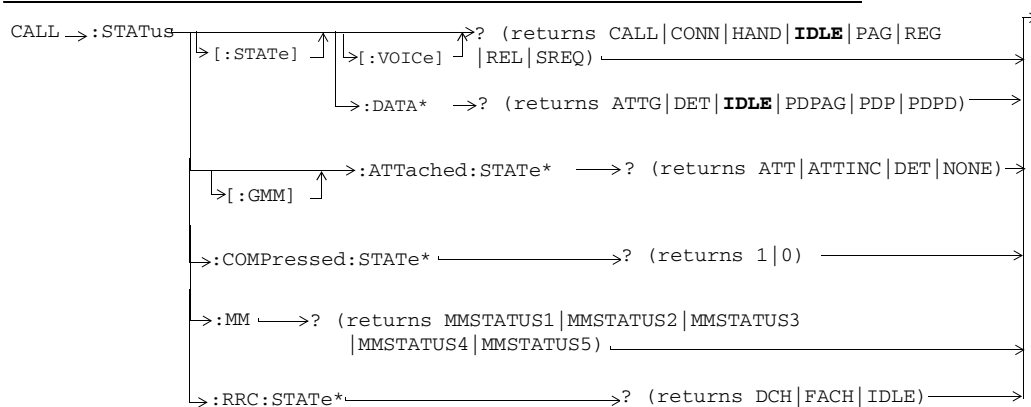

* This command is only applicable to the lab application.

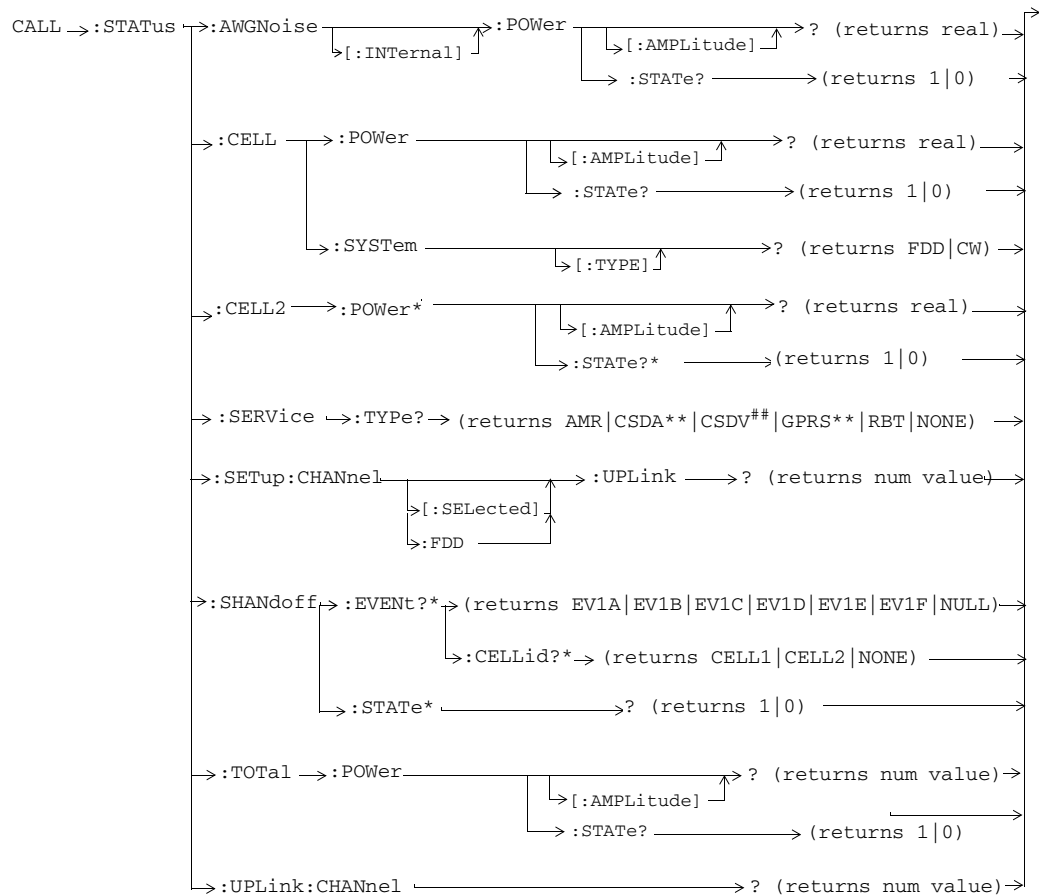

* This command is only applicable to the lab application.

** This query return is only applicable to the lab application.

This query return is only applicable to the lab application or feature-licensed test application.

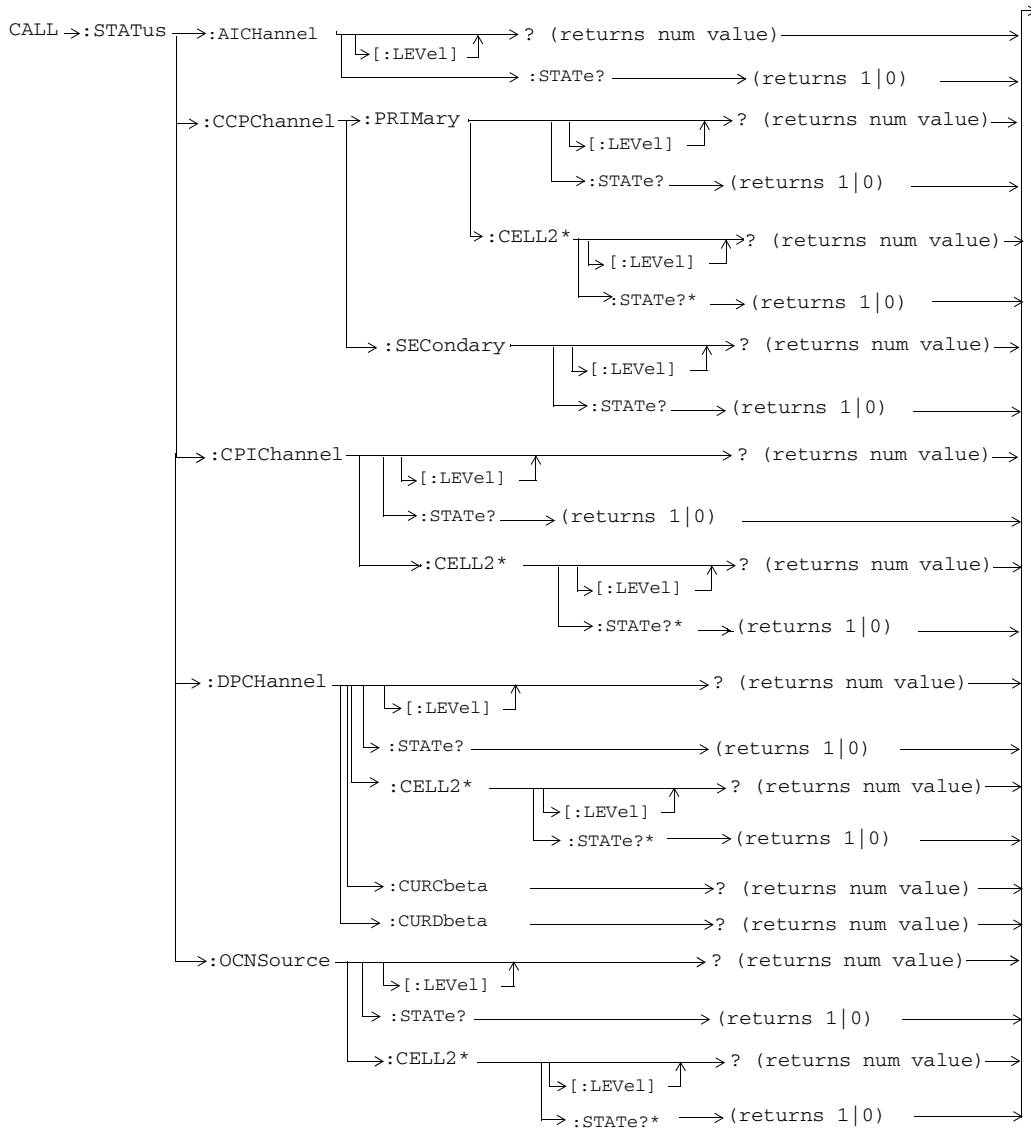

* This command is only applicable to the lab application.

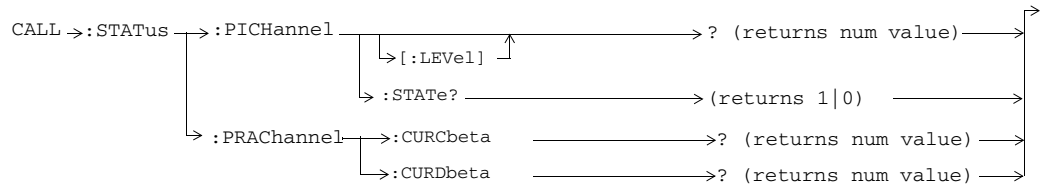

CALL:SYSTem

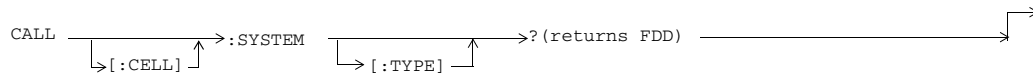

CALL:TMSI

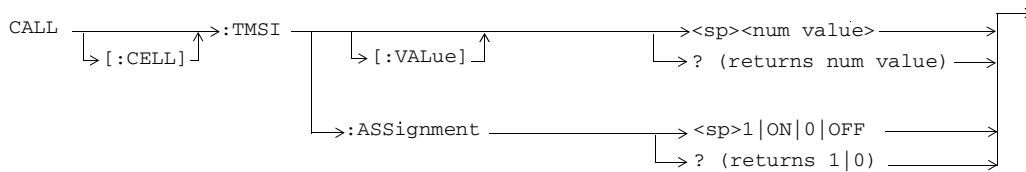

CALL:TOTal:POWer

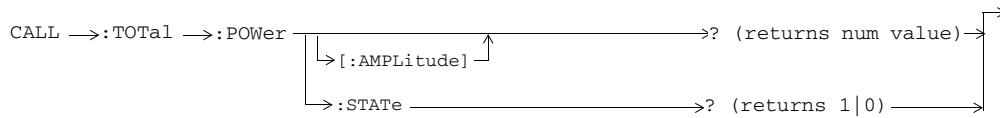

CALL:TRIGger

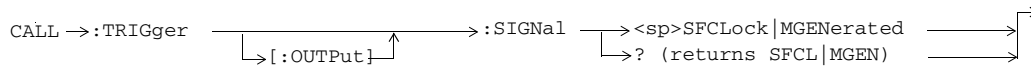

CALL:UINTerferenc

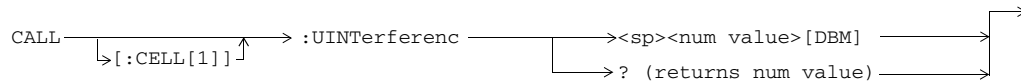

CALL:UPLink

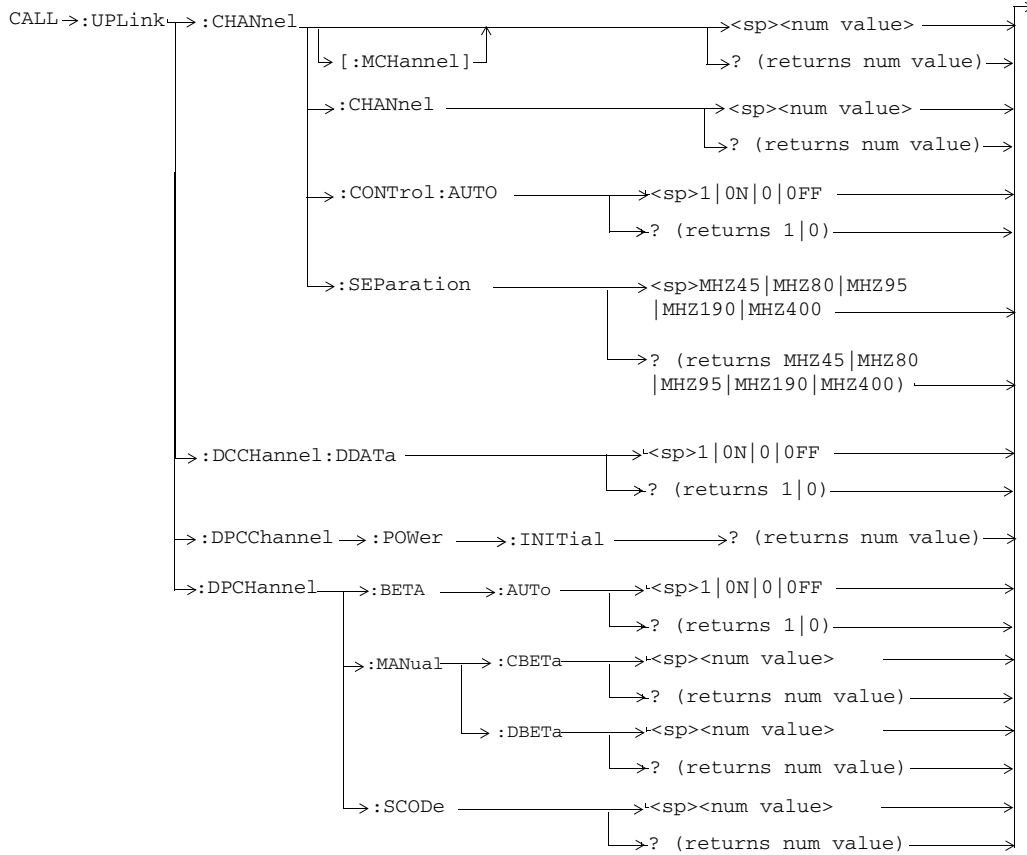

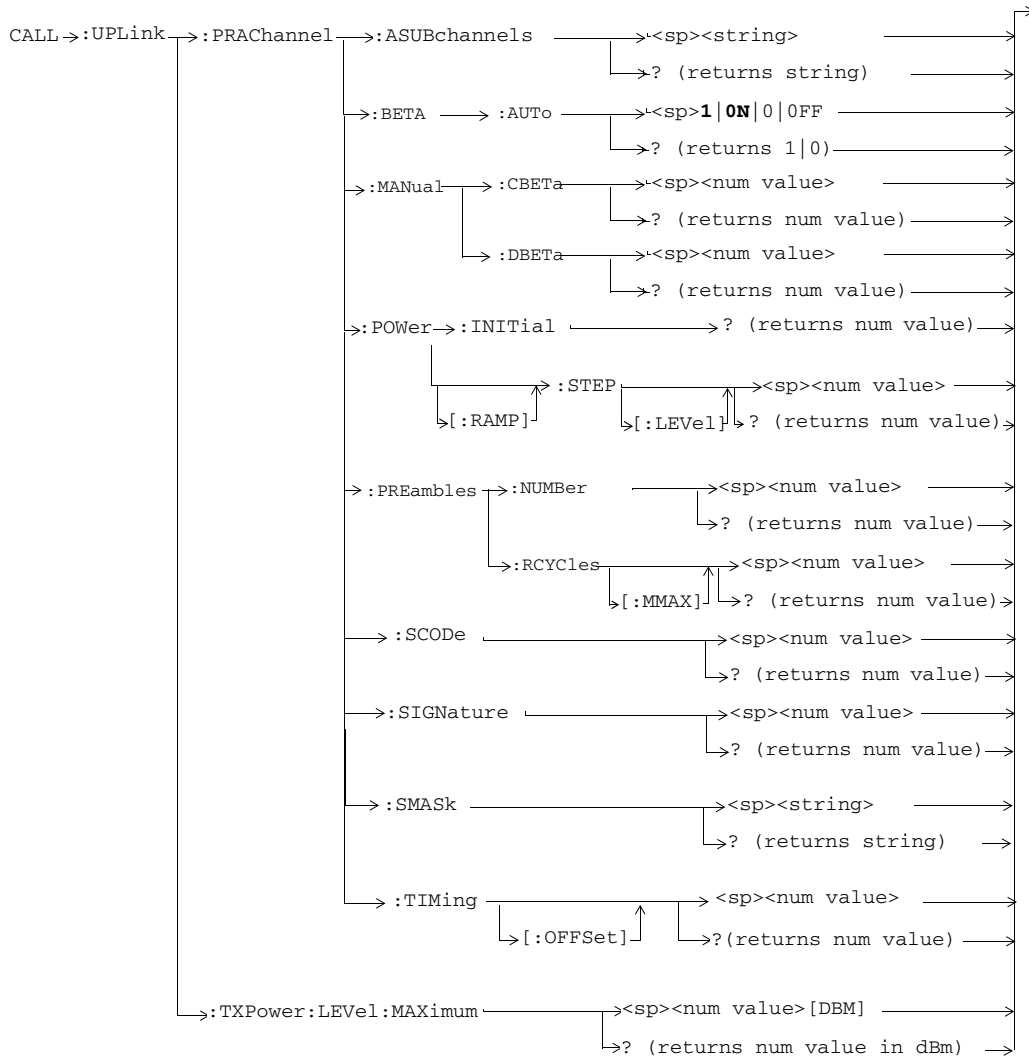

CALL:WAVeform

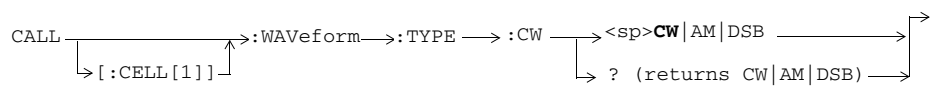

FETCH:AFANalyzer

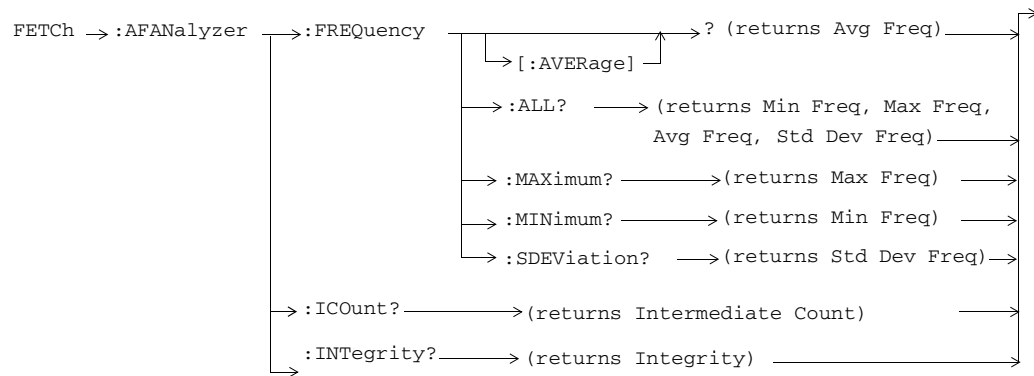
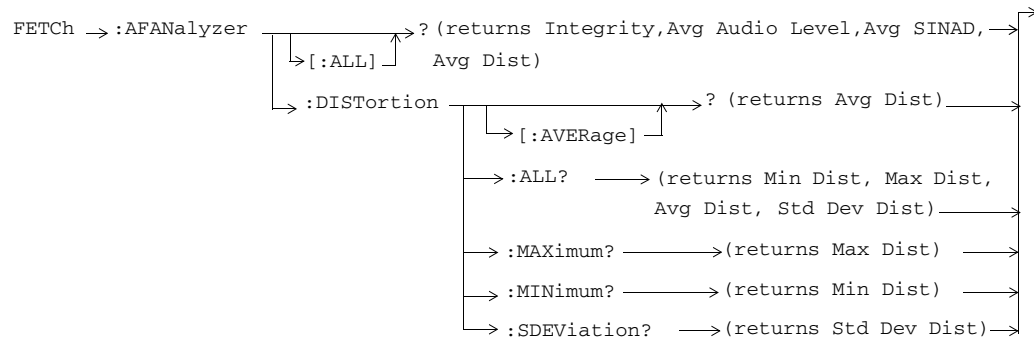

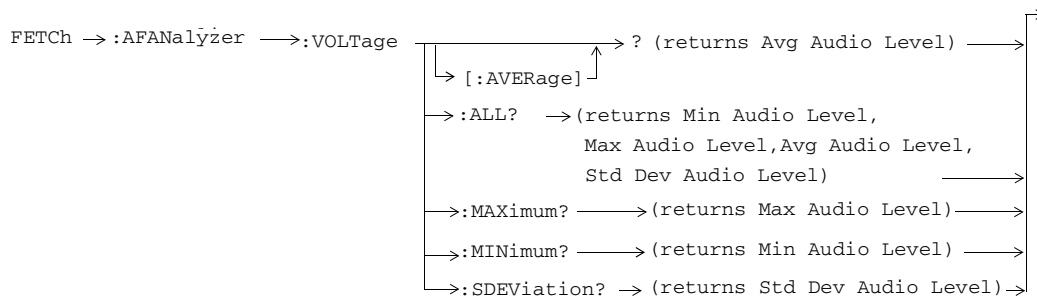
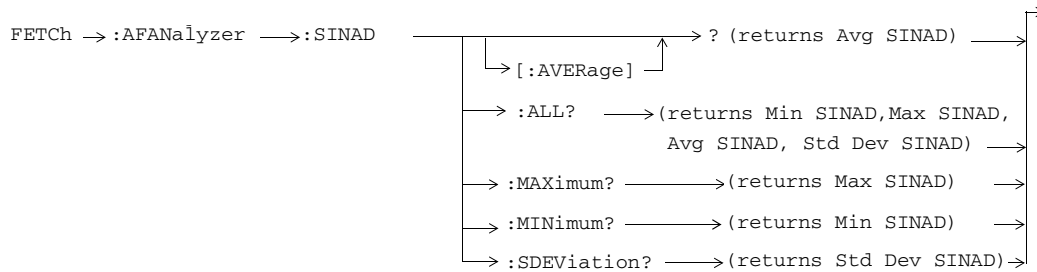

FETCH:FSTability

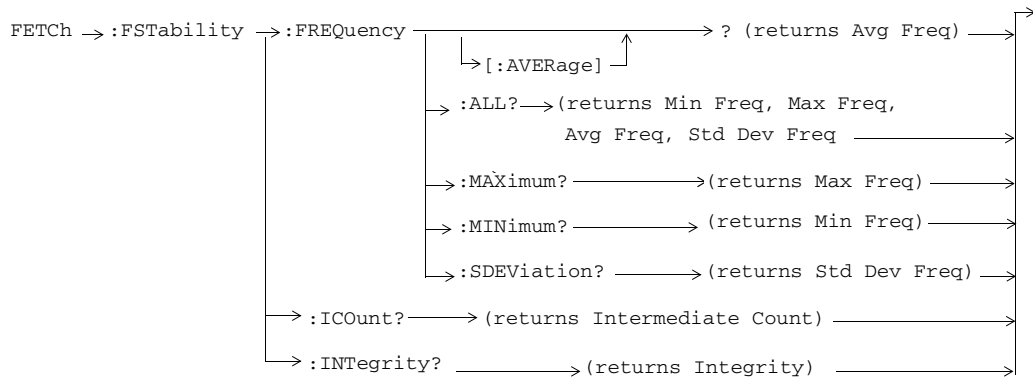
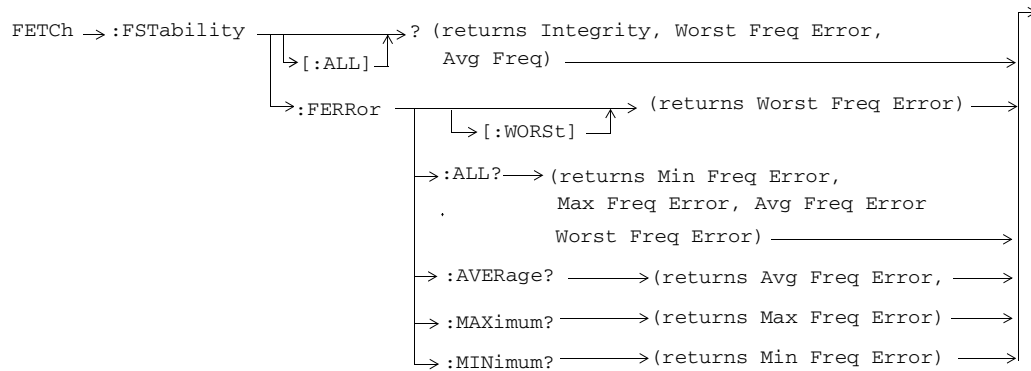

FETCH:SAUDio

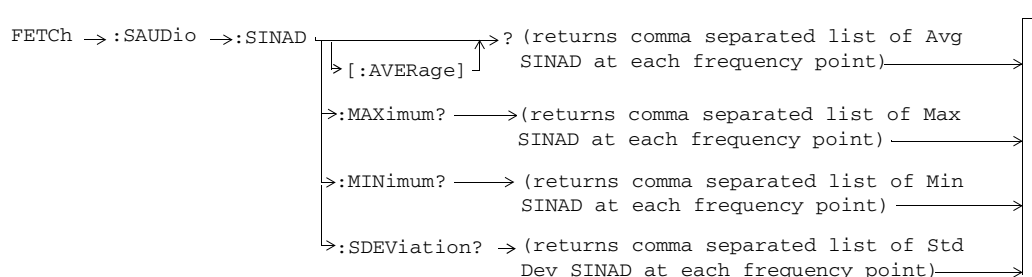
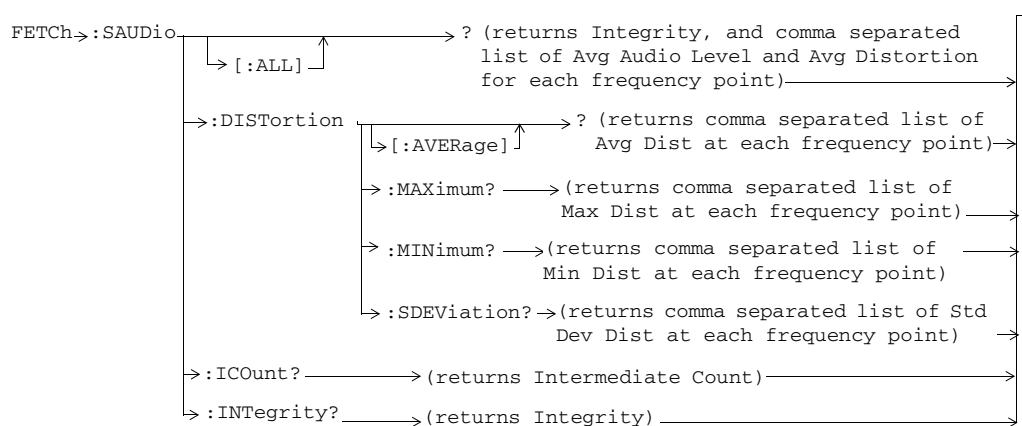

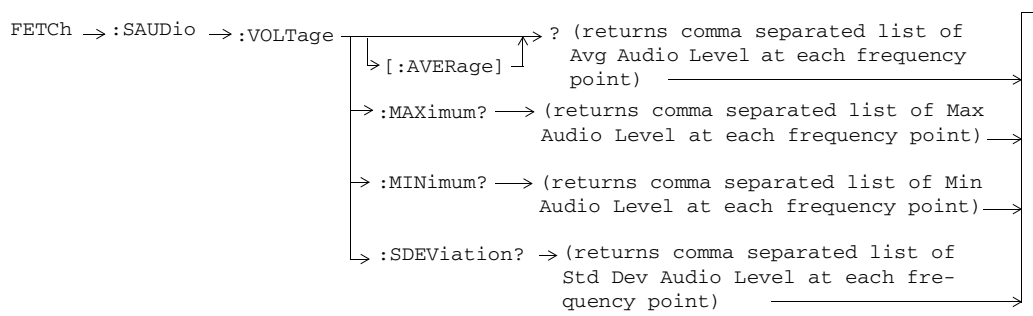

FETCH:SMONitor

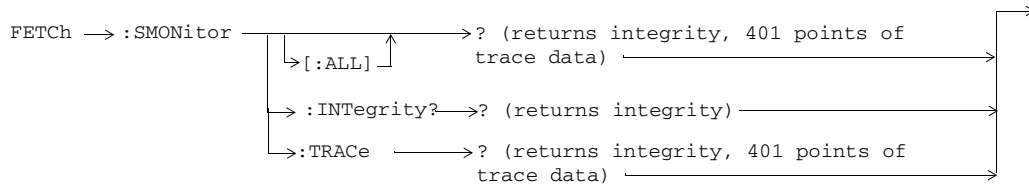

FETCH:WACLeakage

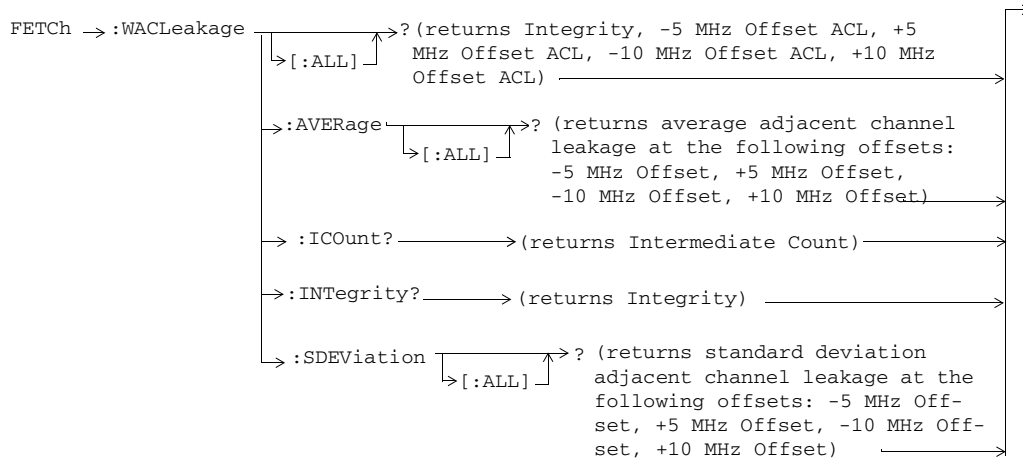

FETCH:WBError

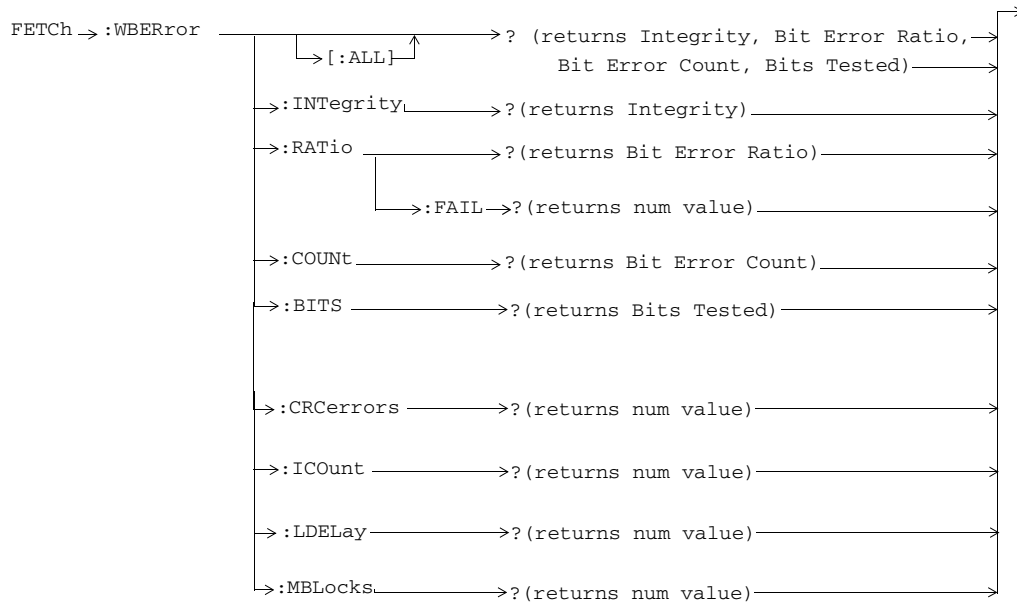

FETCH:WBLerror

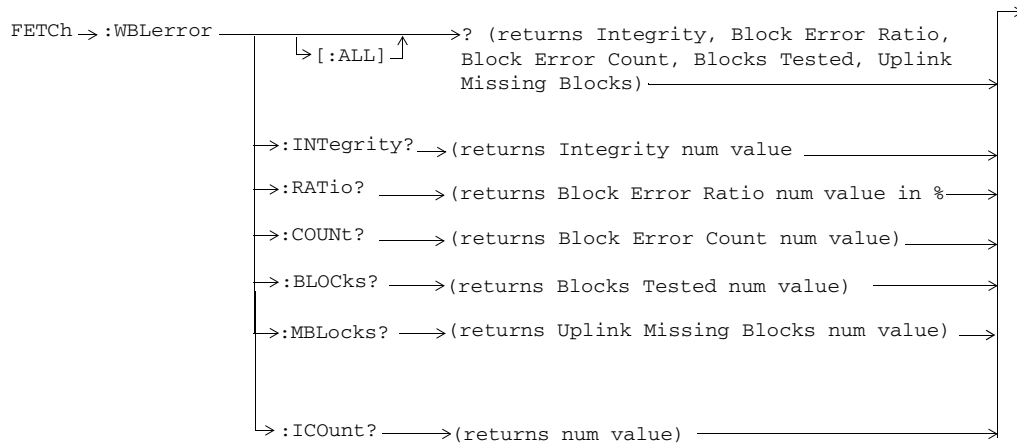

FETCH:WCDomain

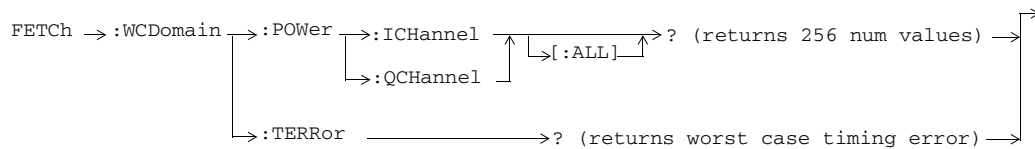
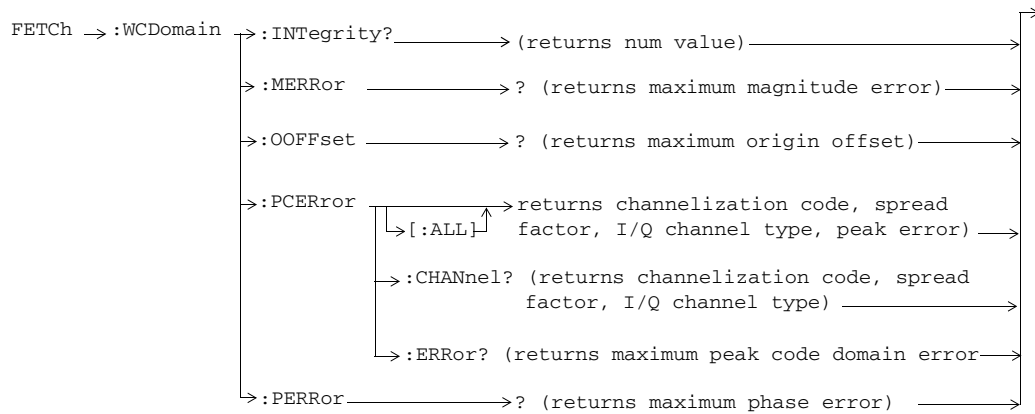
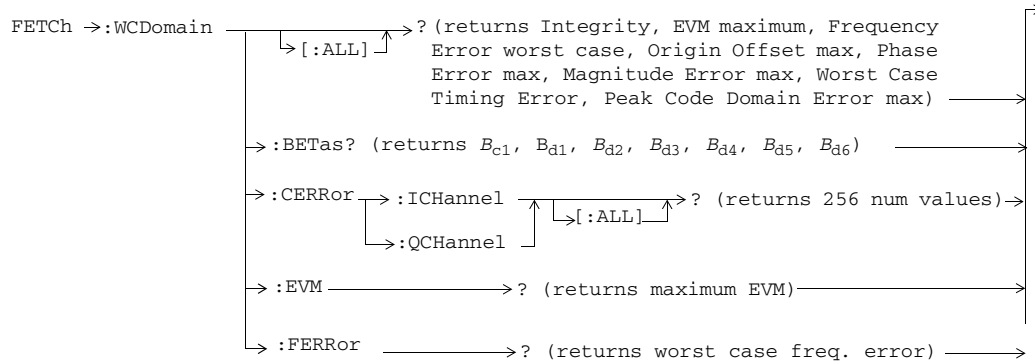

FETCH:WCPower

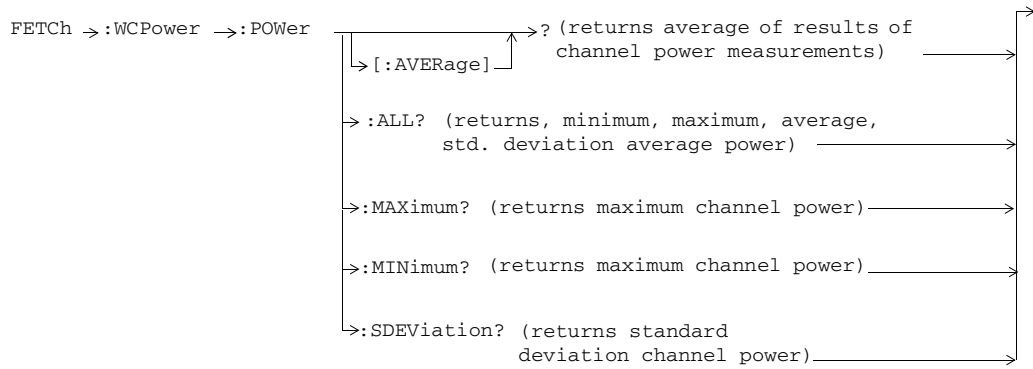
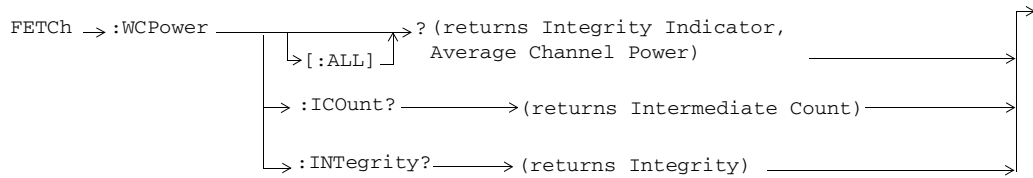

FETCH:WCTFormat

This section is only applicable to the lab application.

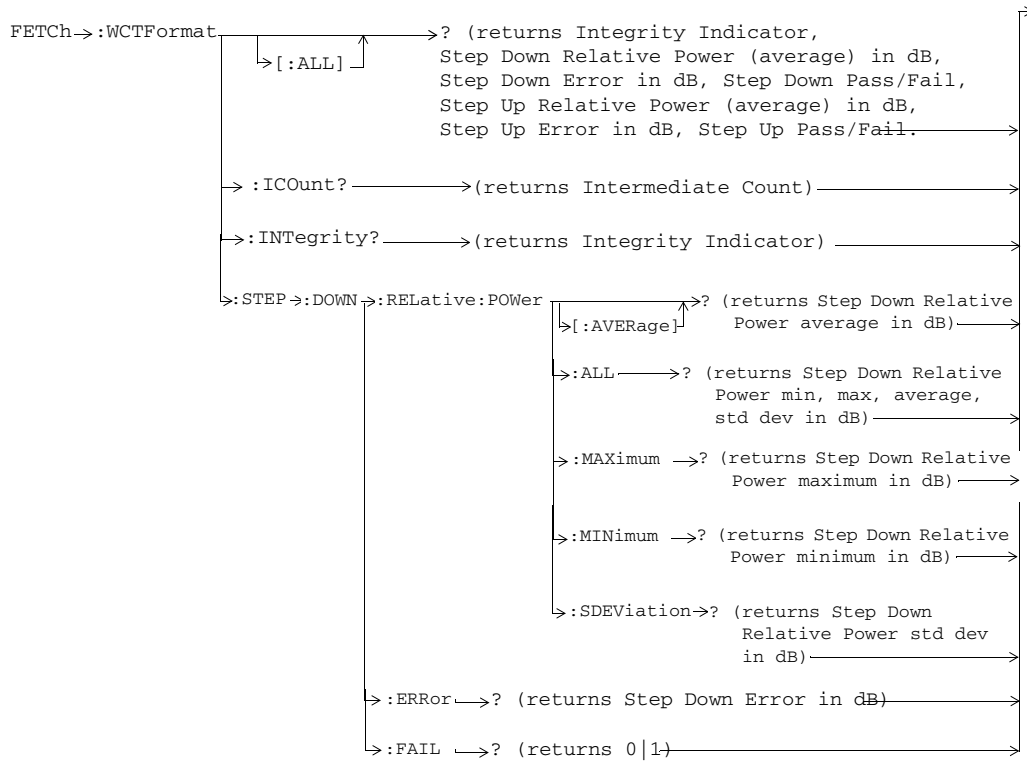

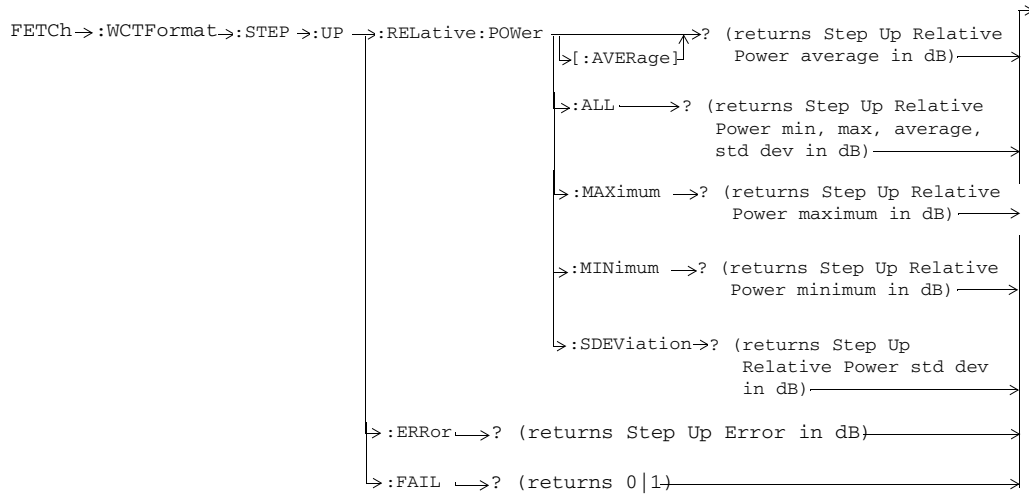

FETCH:WDPAnalysis

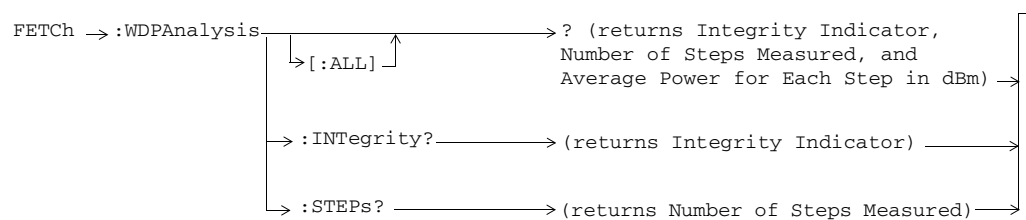

FETCH:WILPower

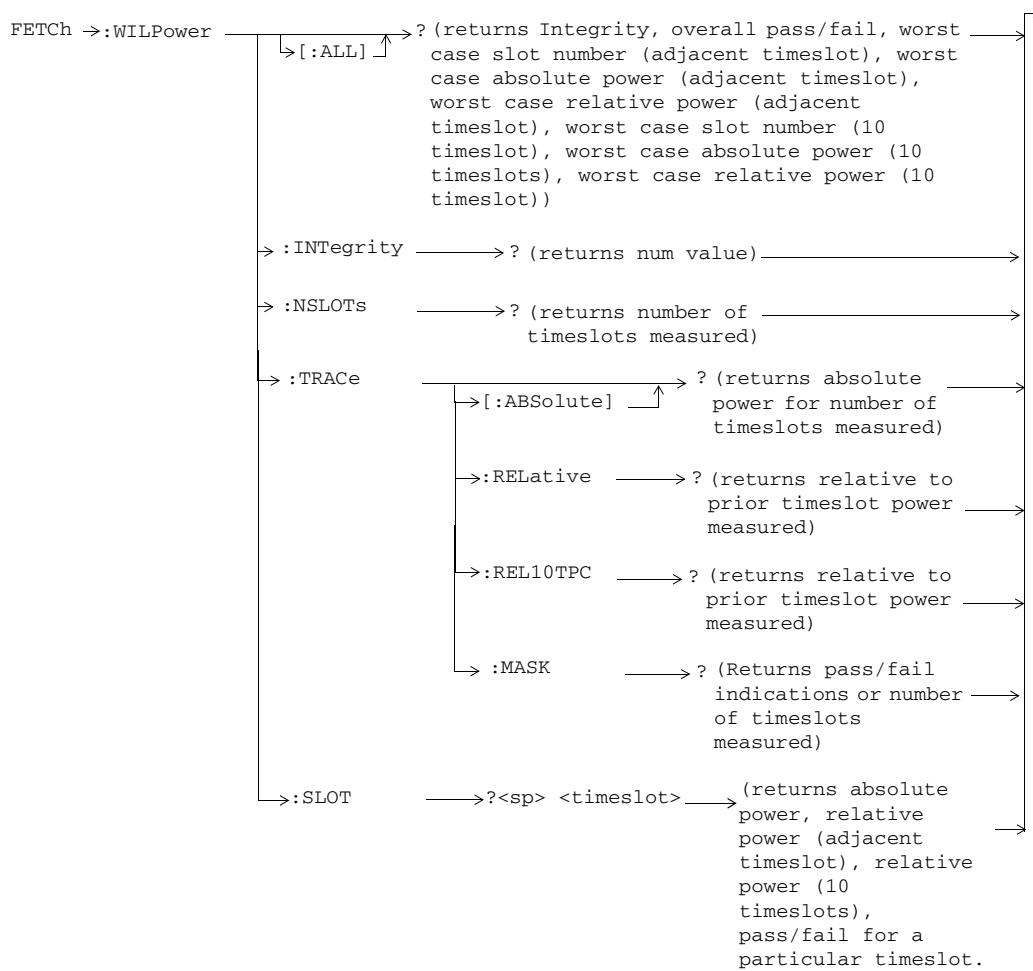

FETCH:WIQTuning

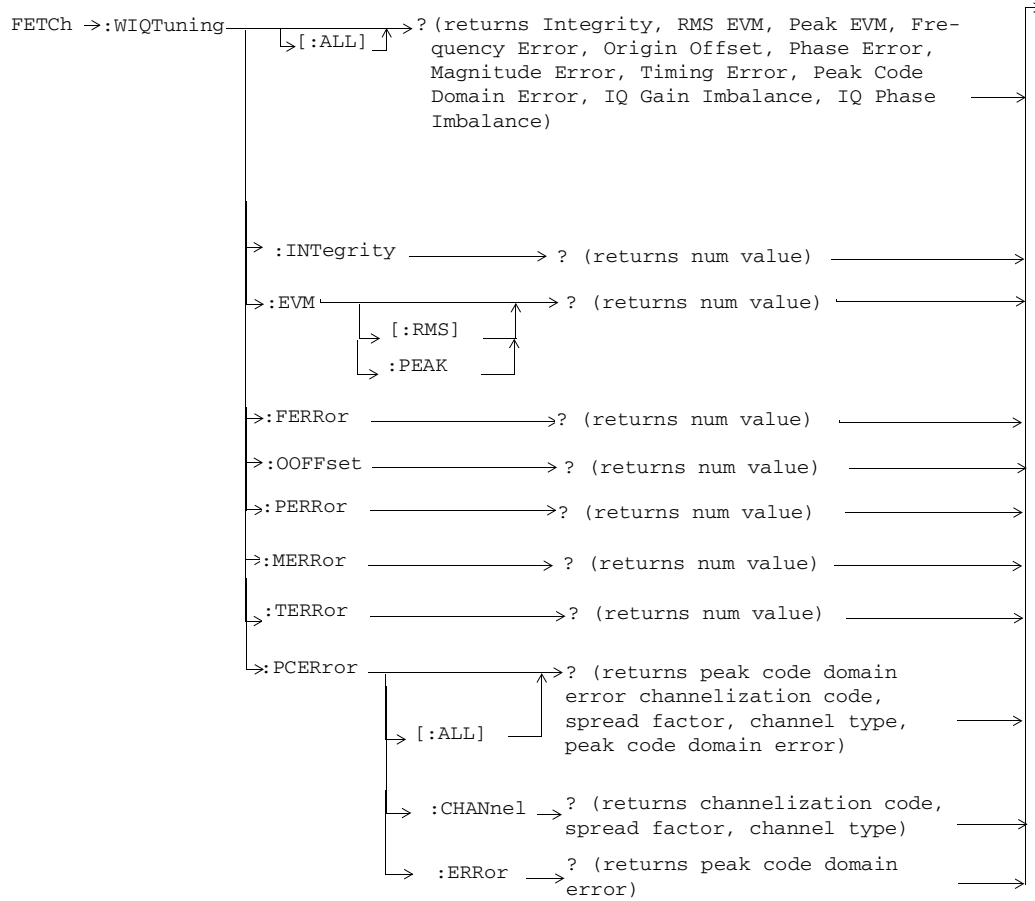

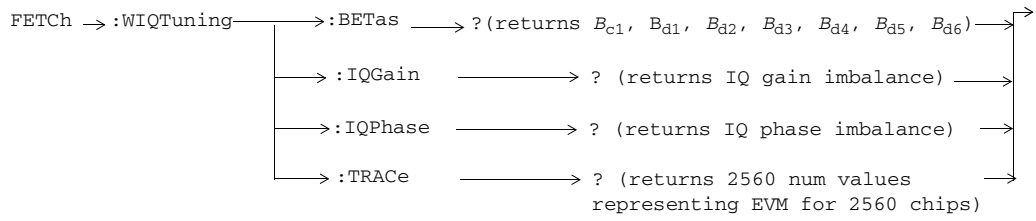

FETCH:WOBWidth

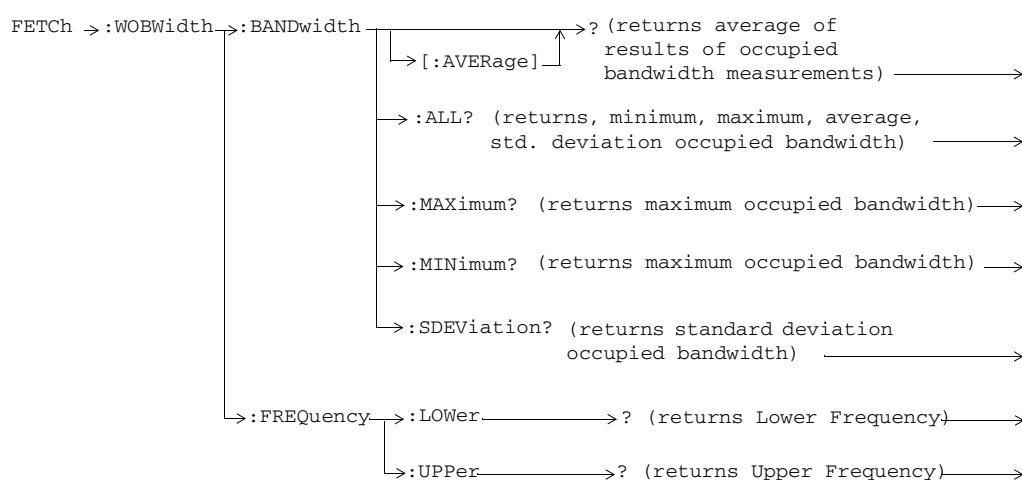
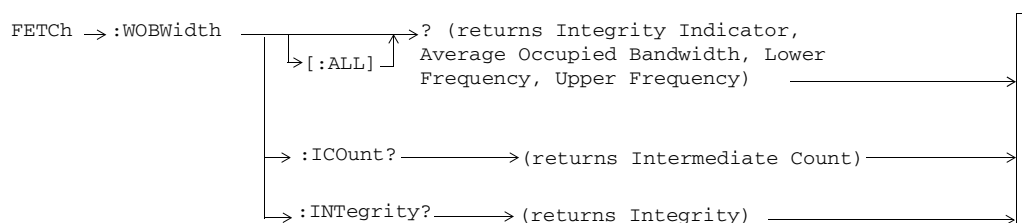

FETCH:WOOPower

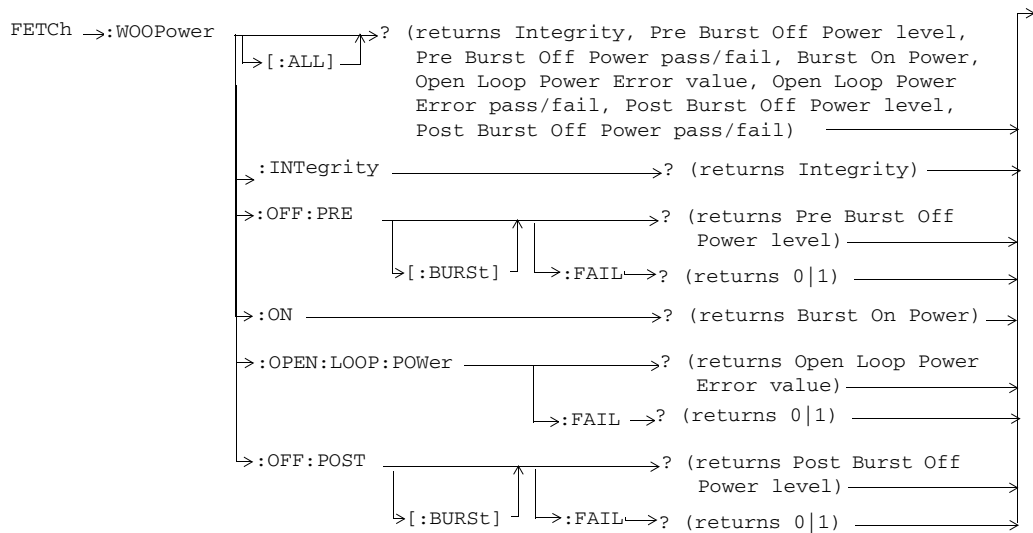

FETCH:WPDIscon

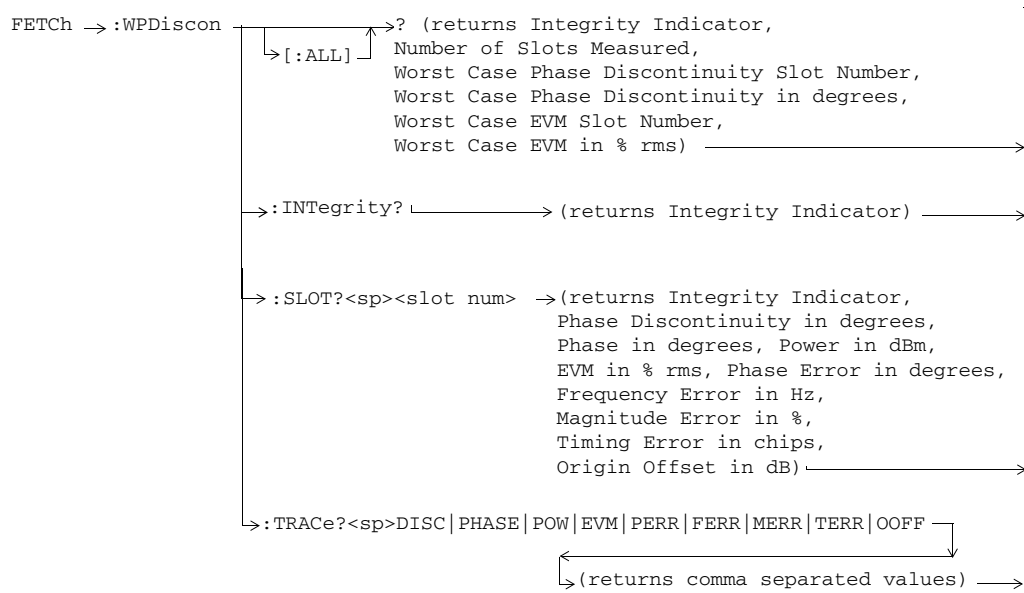

FETCH:WPPAnalysis

This section is applicable to the lab application only.

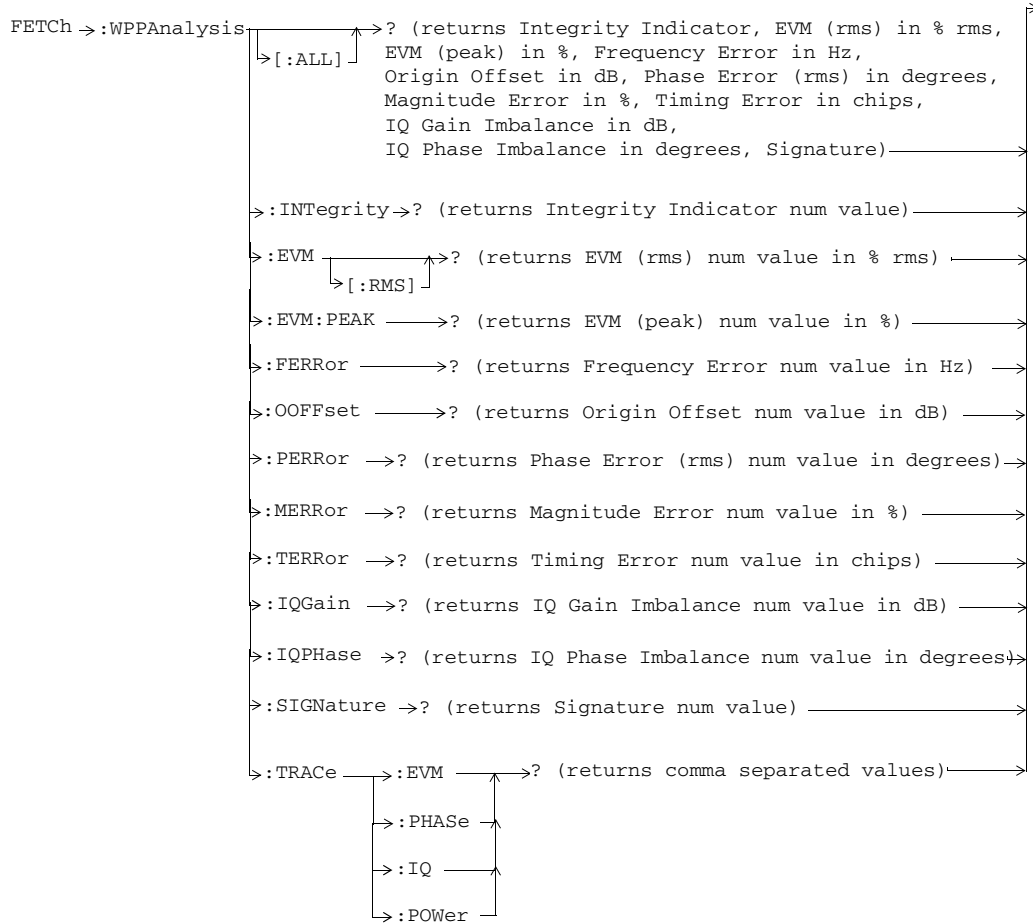

FETCH:WSEMask

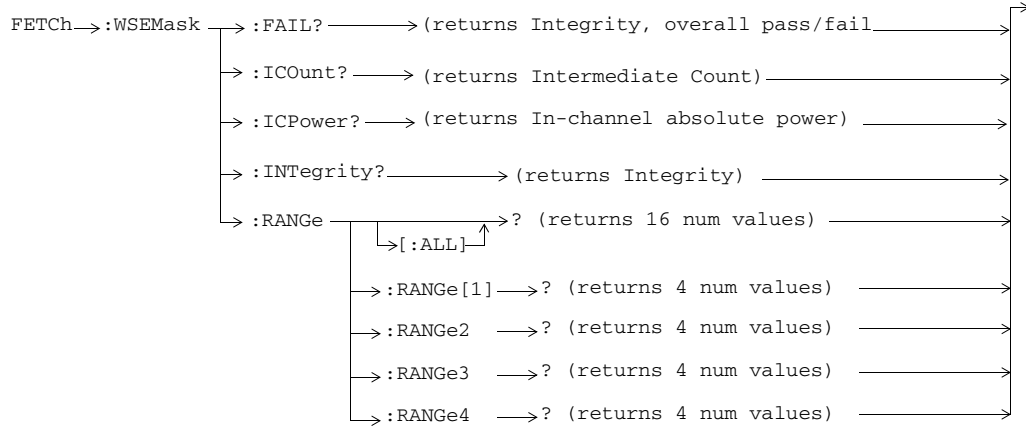
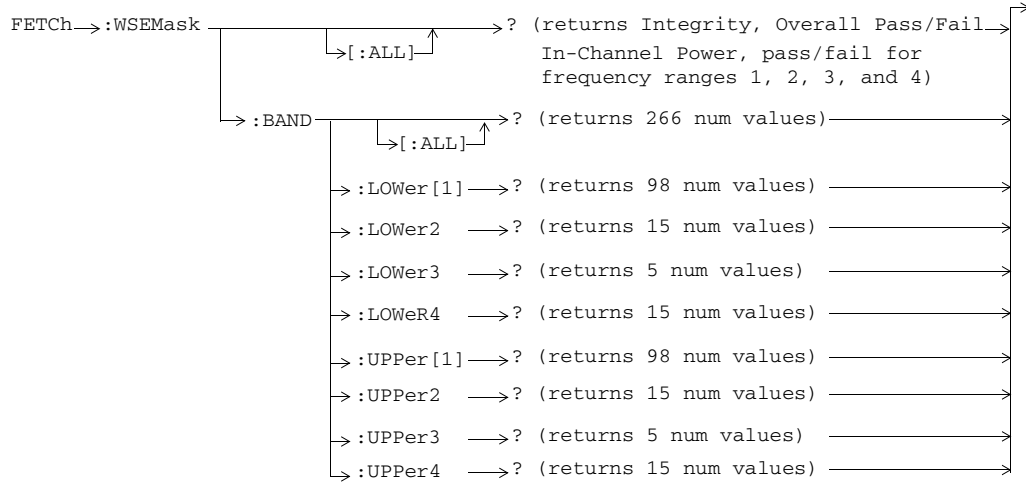

FETCH:WTDPower

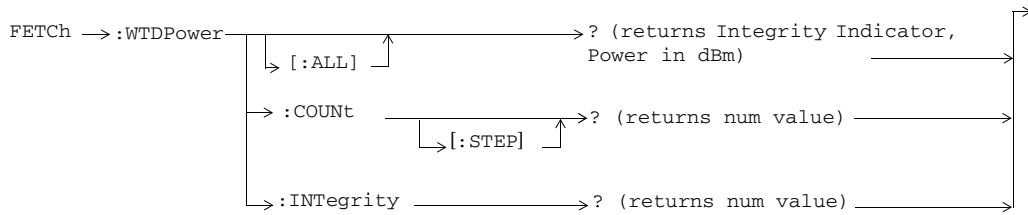

FETCH:WTPower

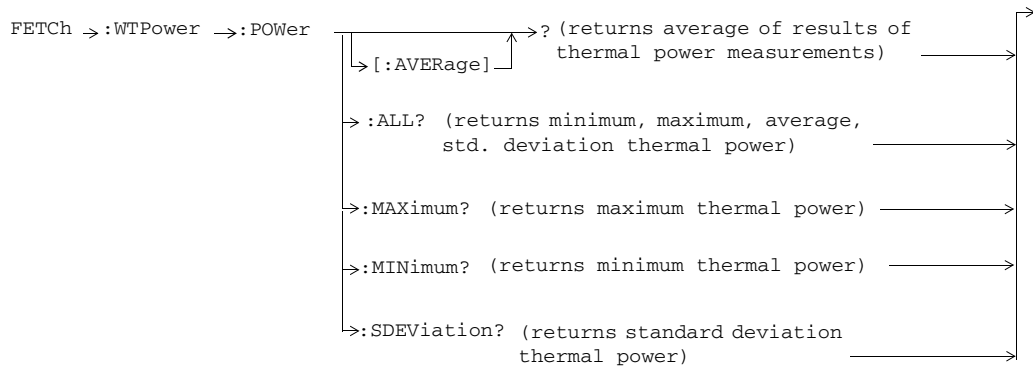
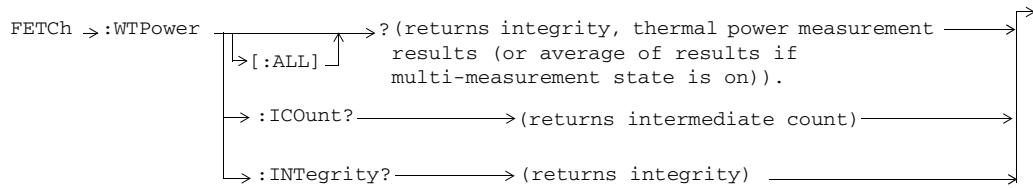

FETCH:WWQuality

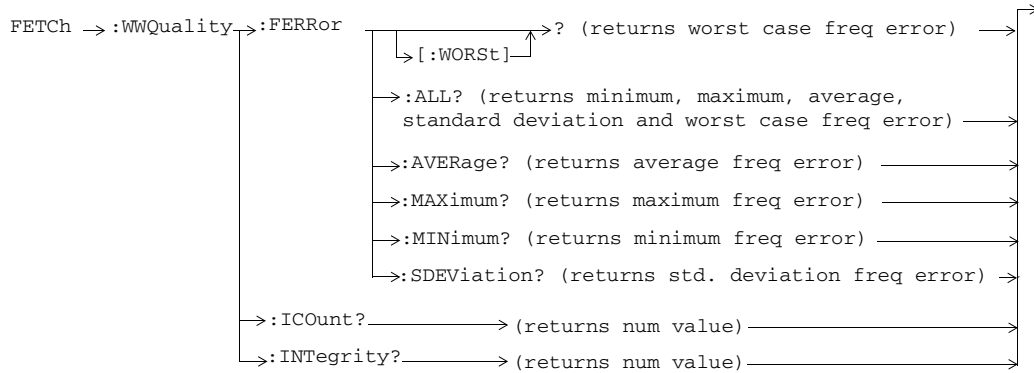
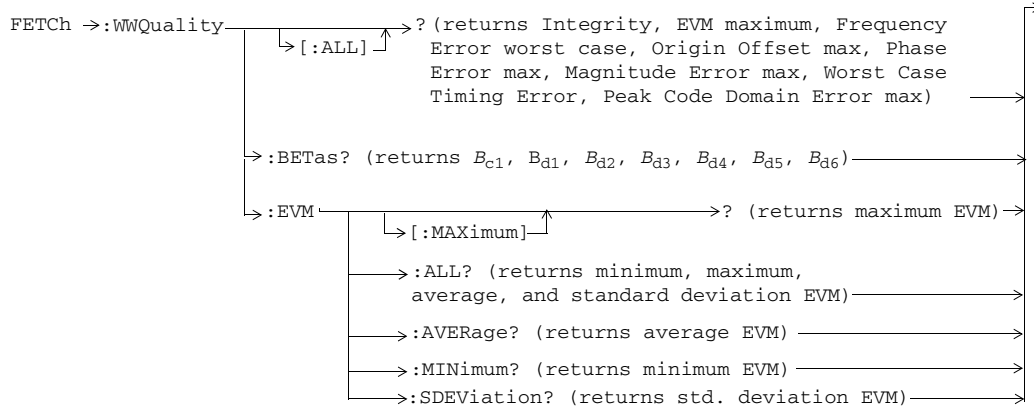

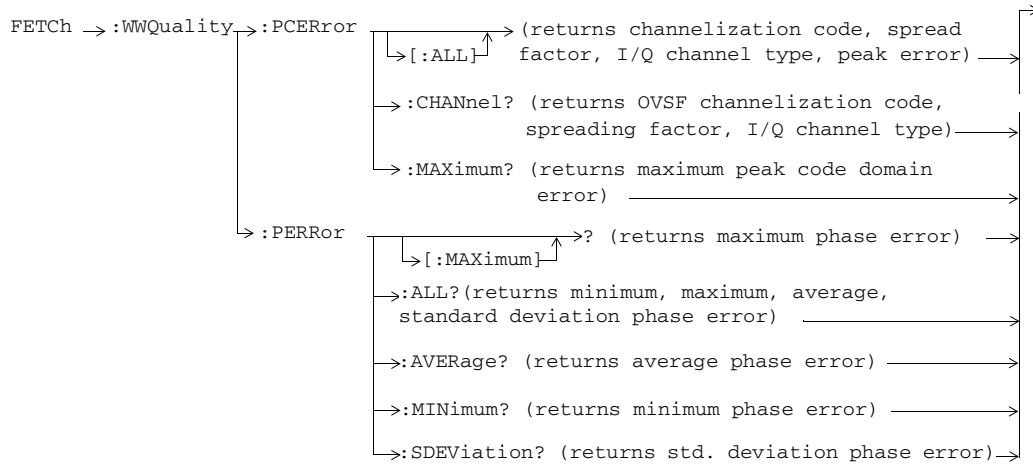
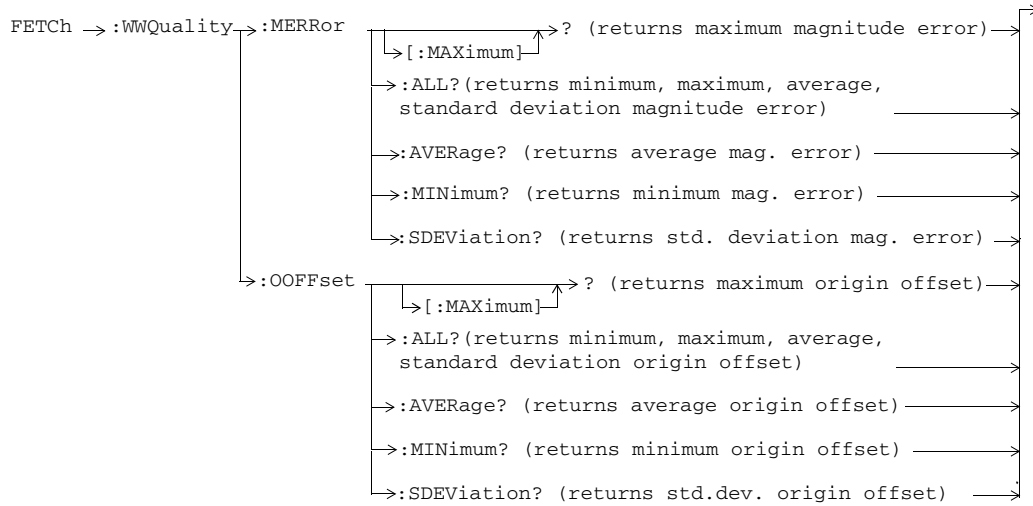

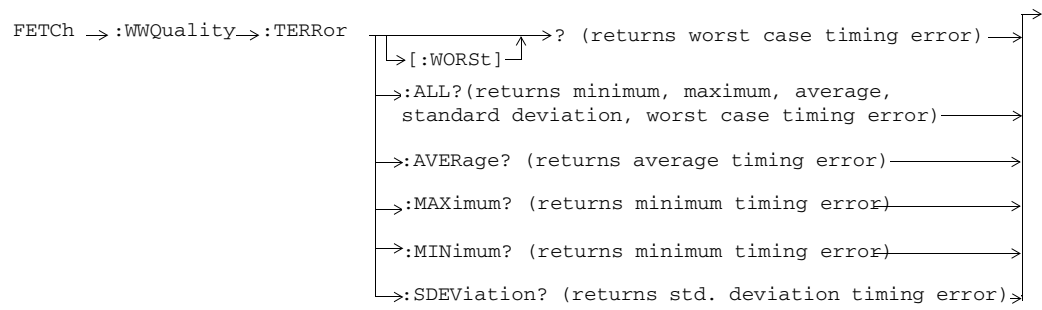

INITiate

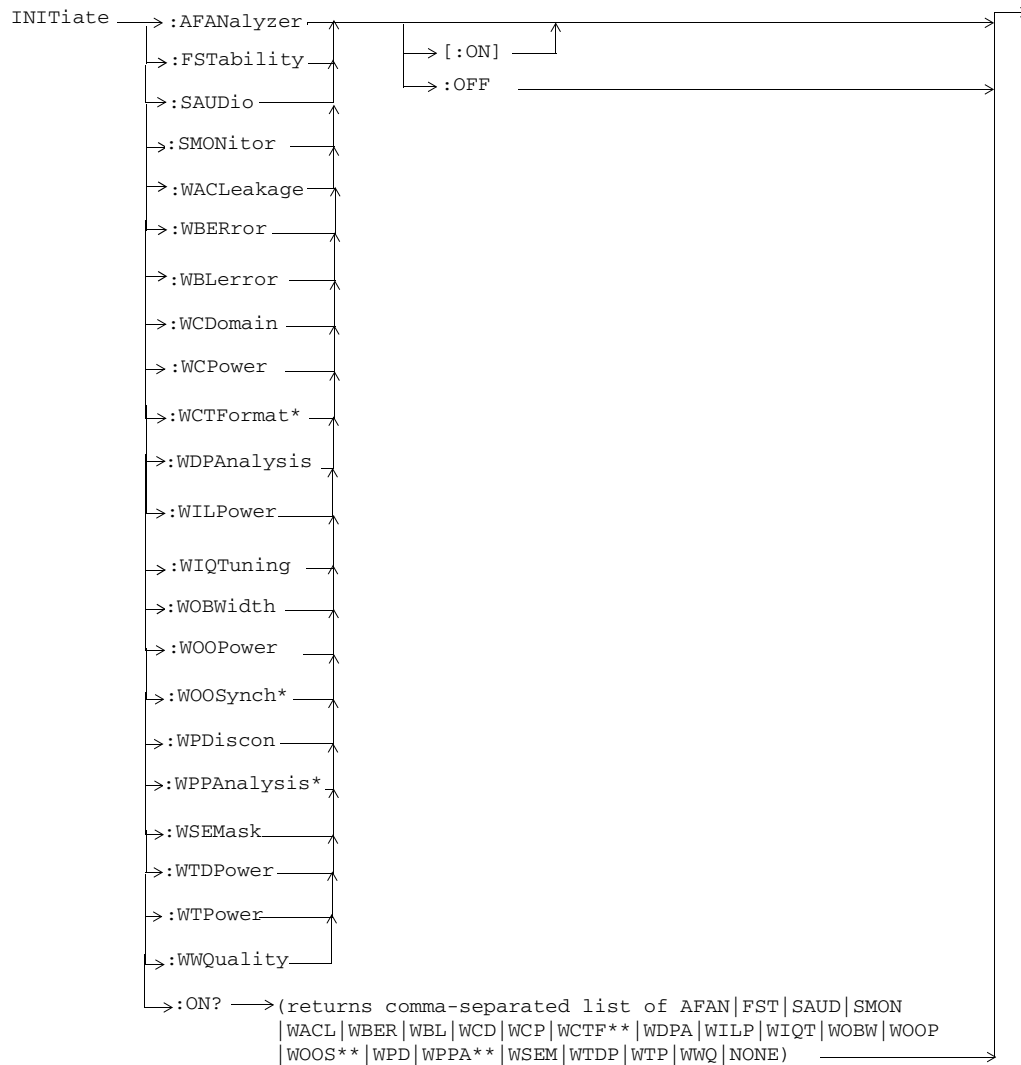

* This command is only applicable to the lab application.

** This query return is only applicable to the lab application.

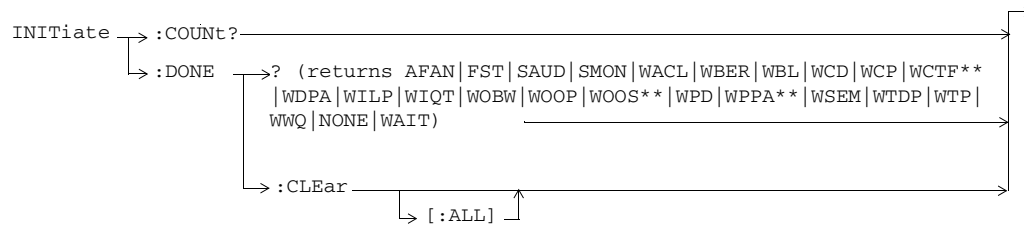

** This query return is only applicable to the lab application.

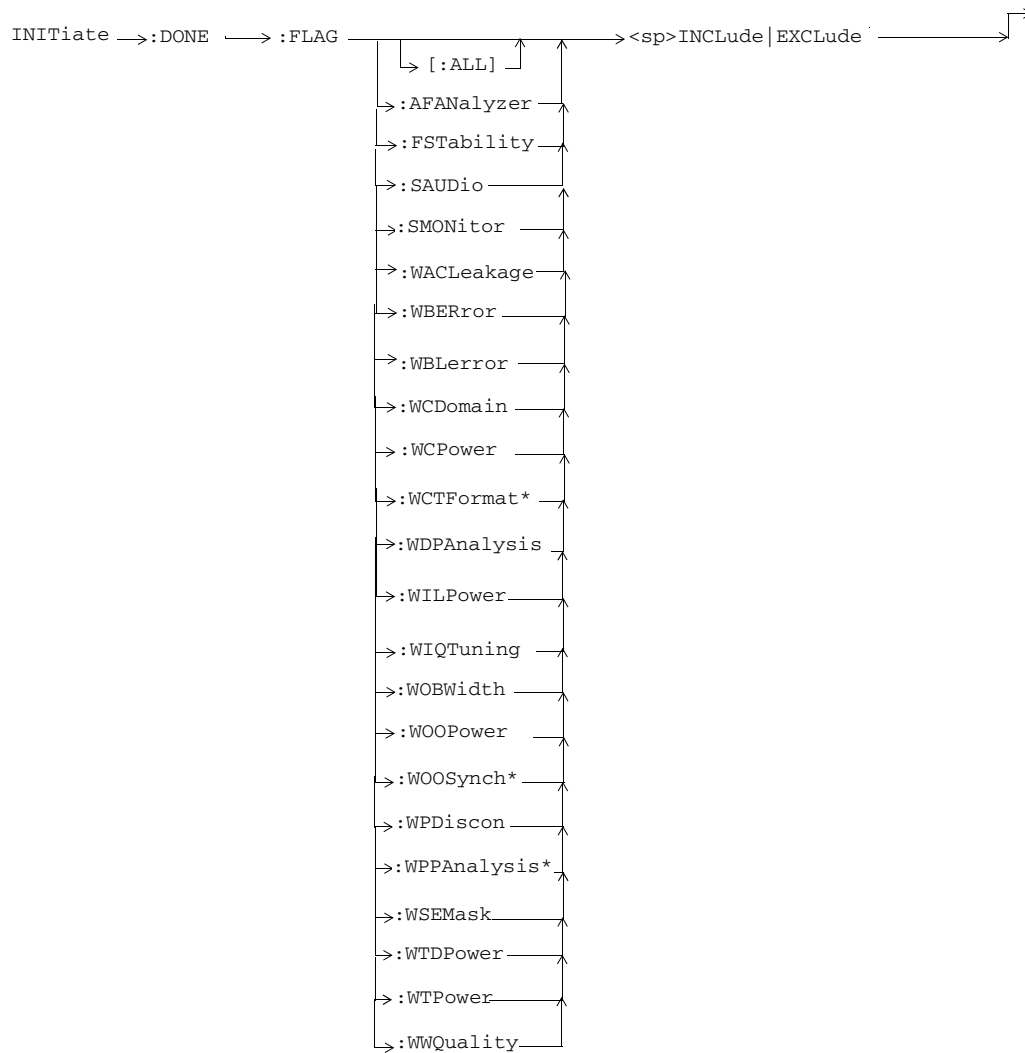

* This command is only applicable to the lab application.

READ

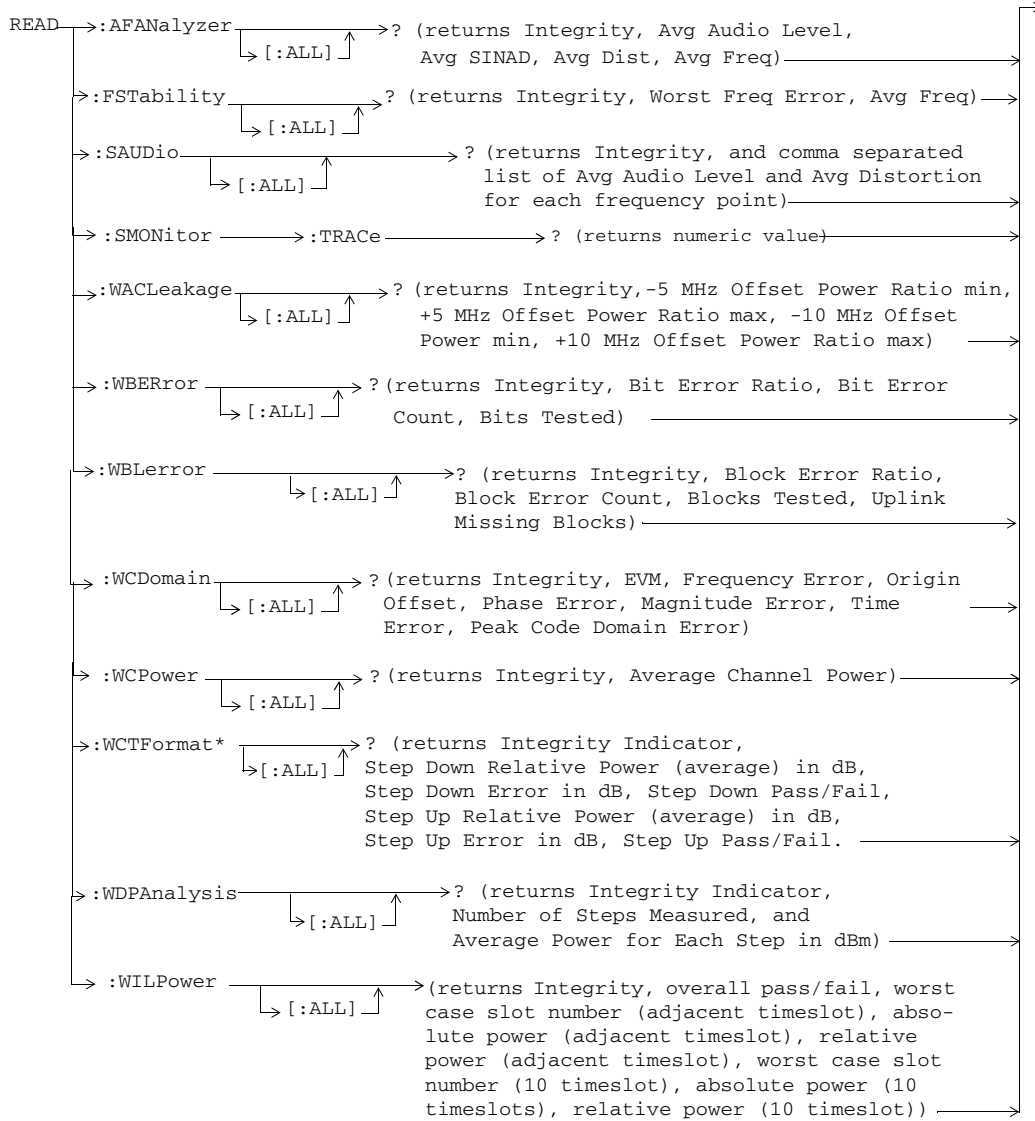

* This query is only applicable to the lab application.

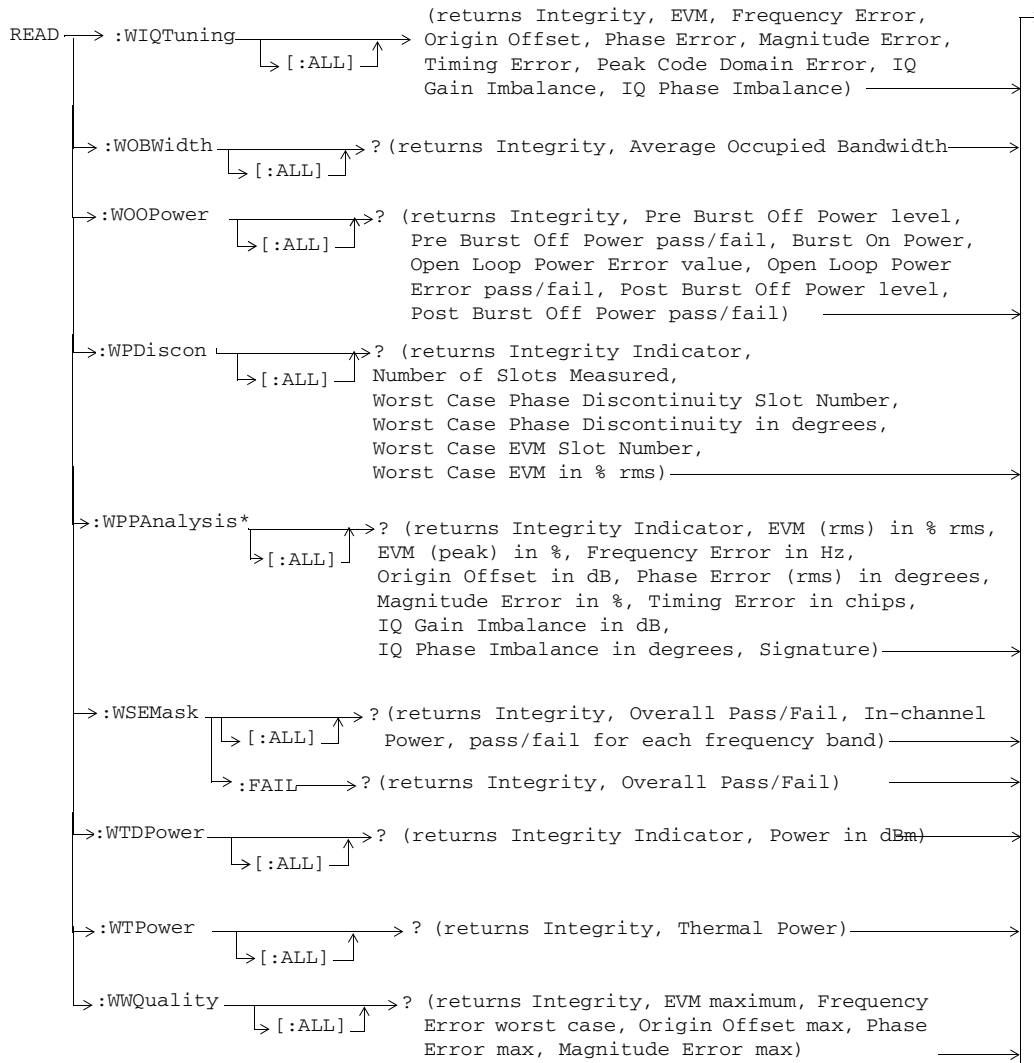

* This query is only applicable to the lab application.

SETup:AFANalyzer

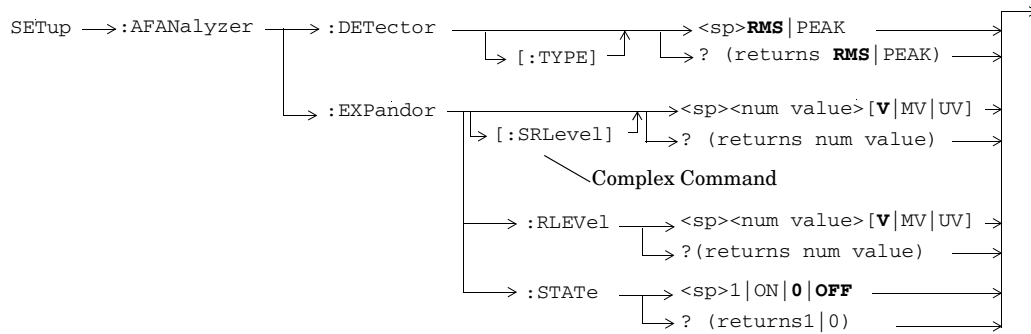
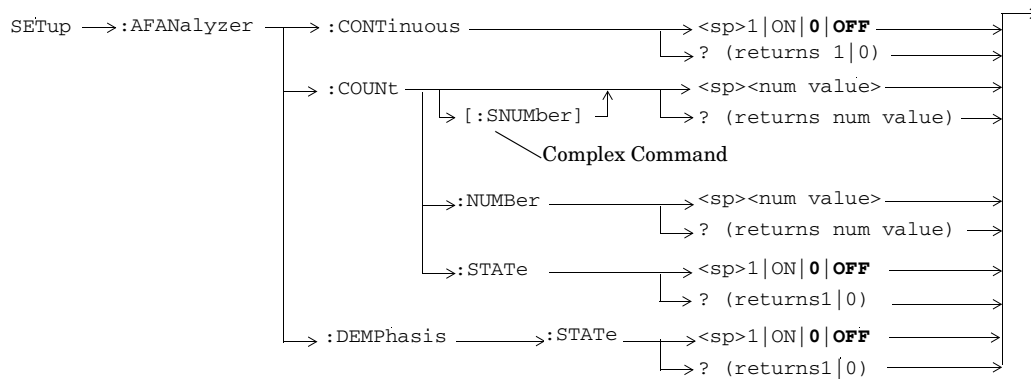

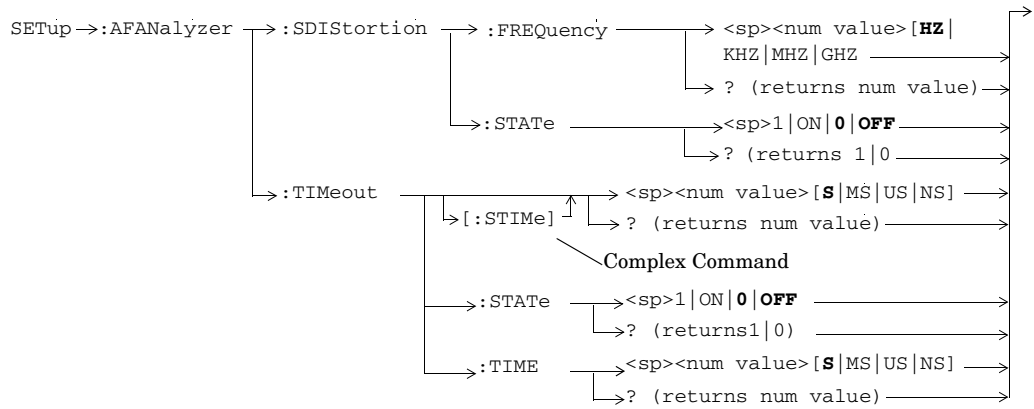
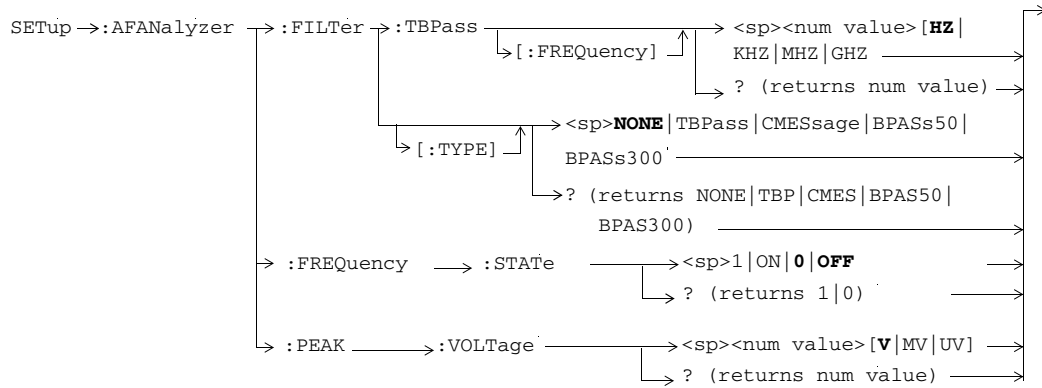

SETup:FSTability

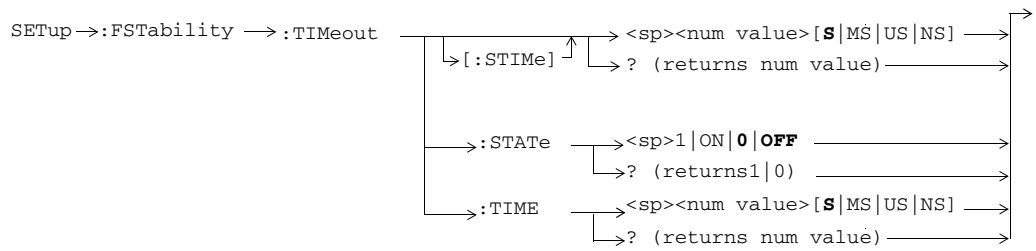
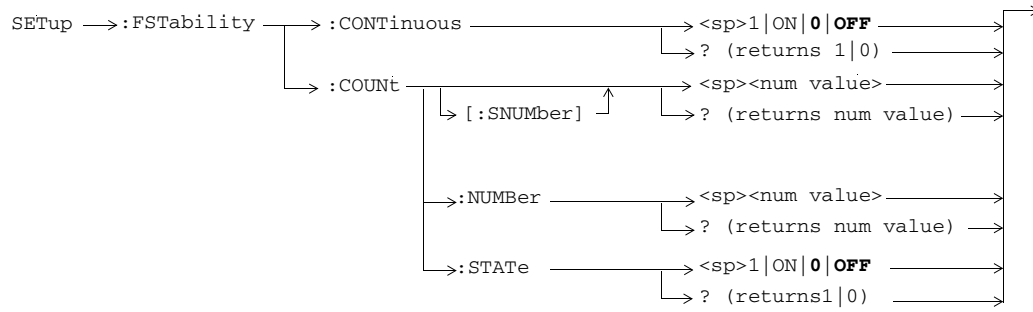

SETup:SAUDio

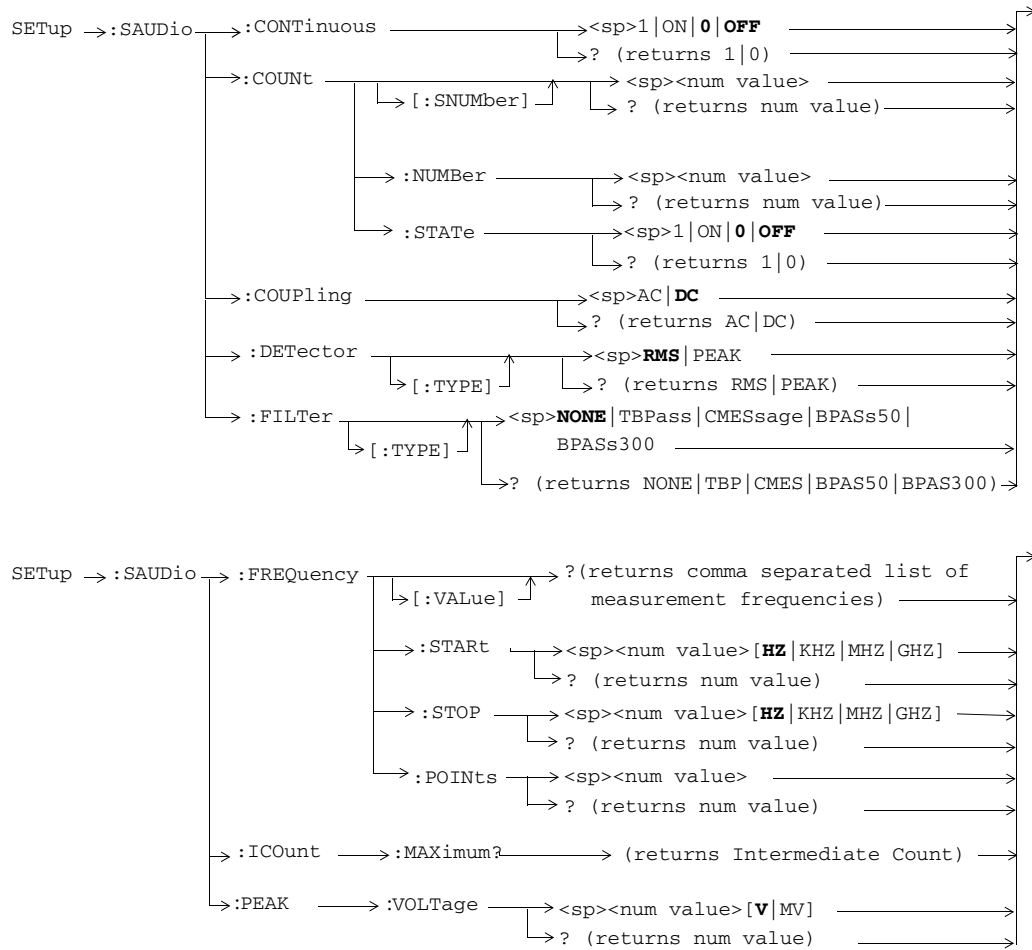

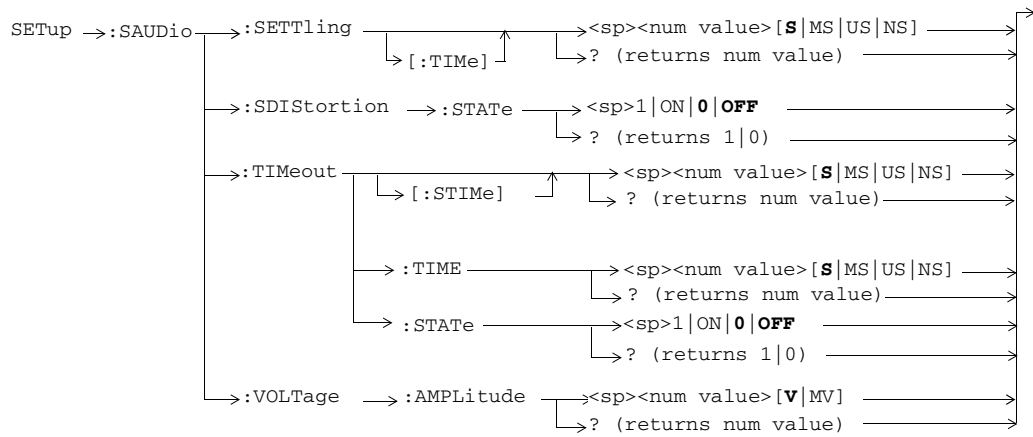

SETup:SMONitor

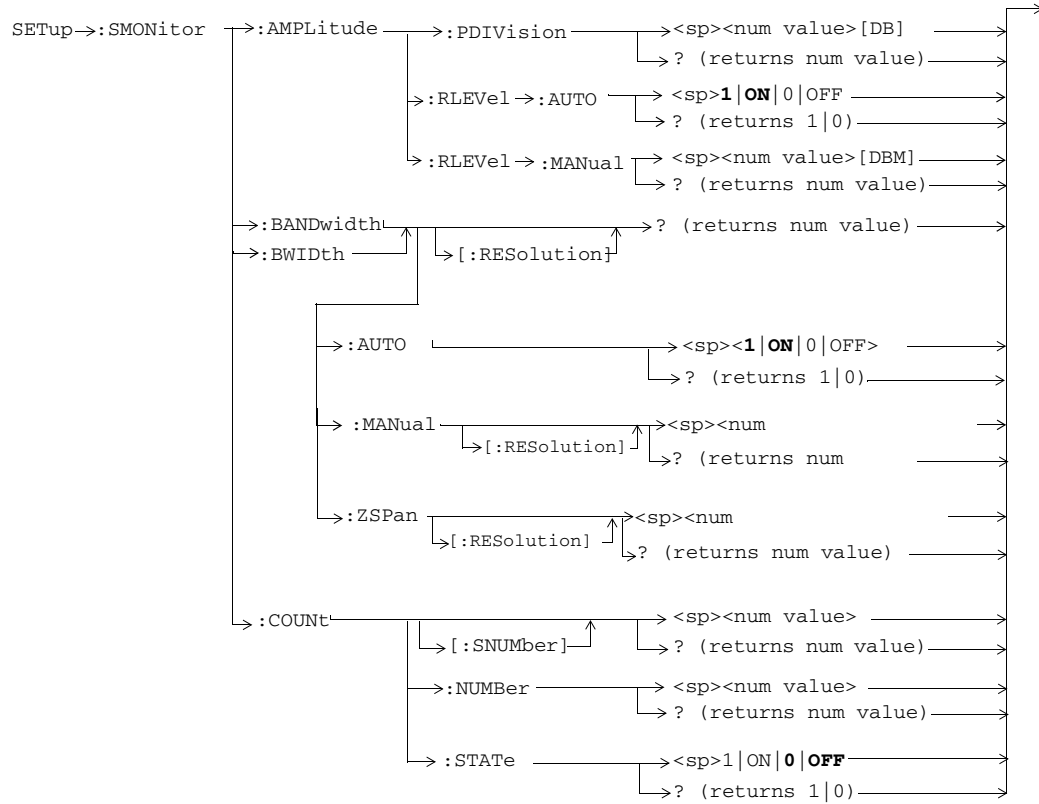

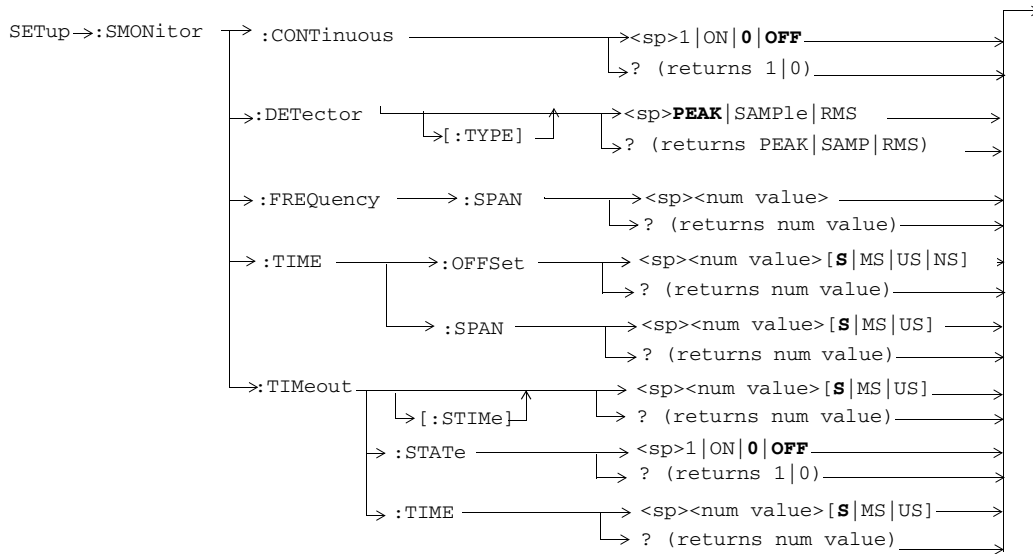

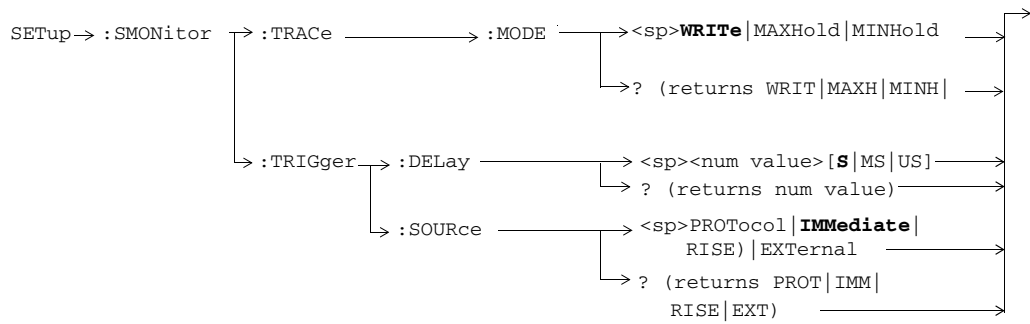

SETup:WACLeakage

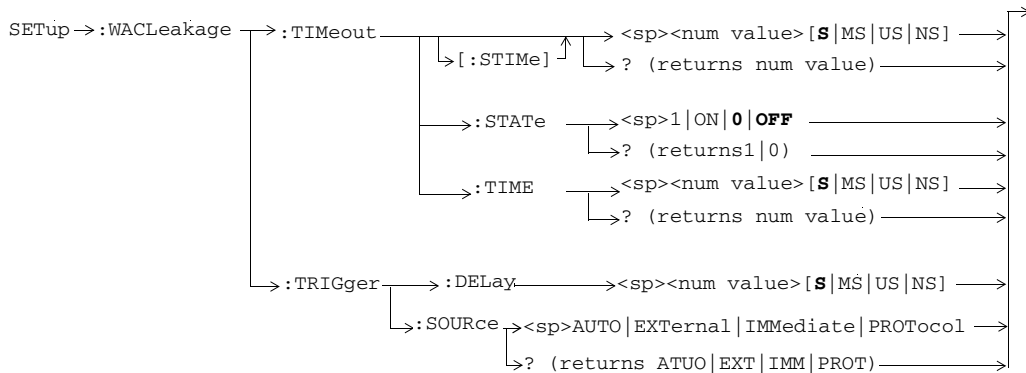
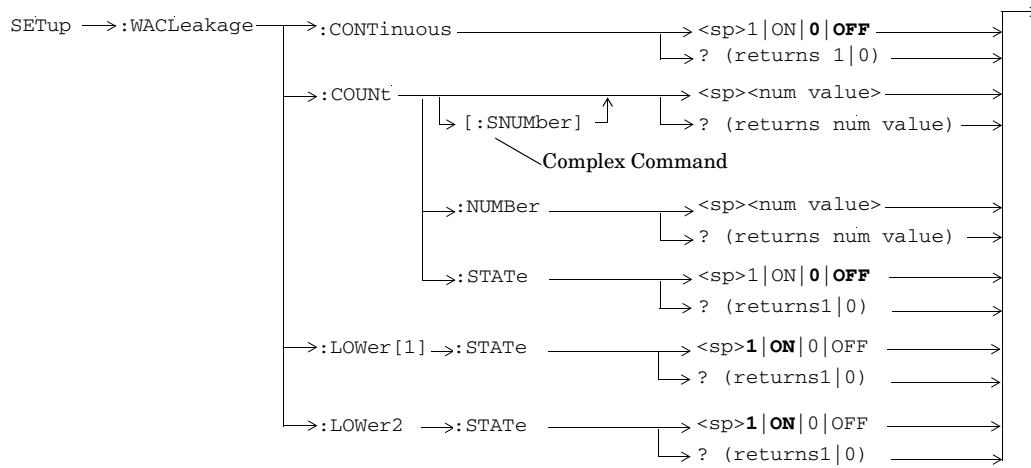

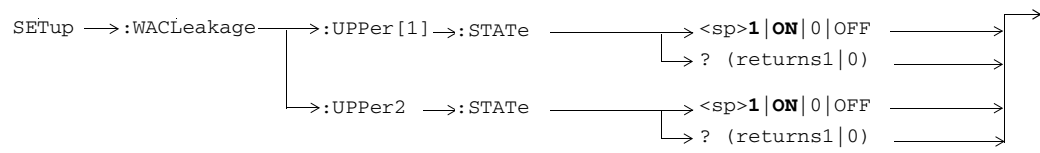

SETup:WBERror

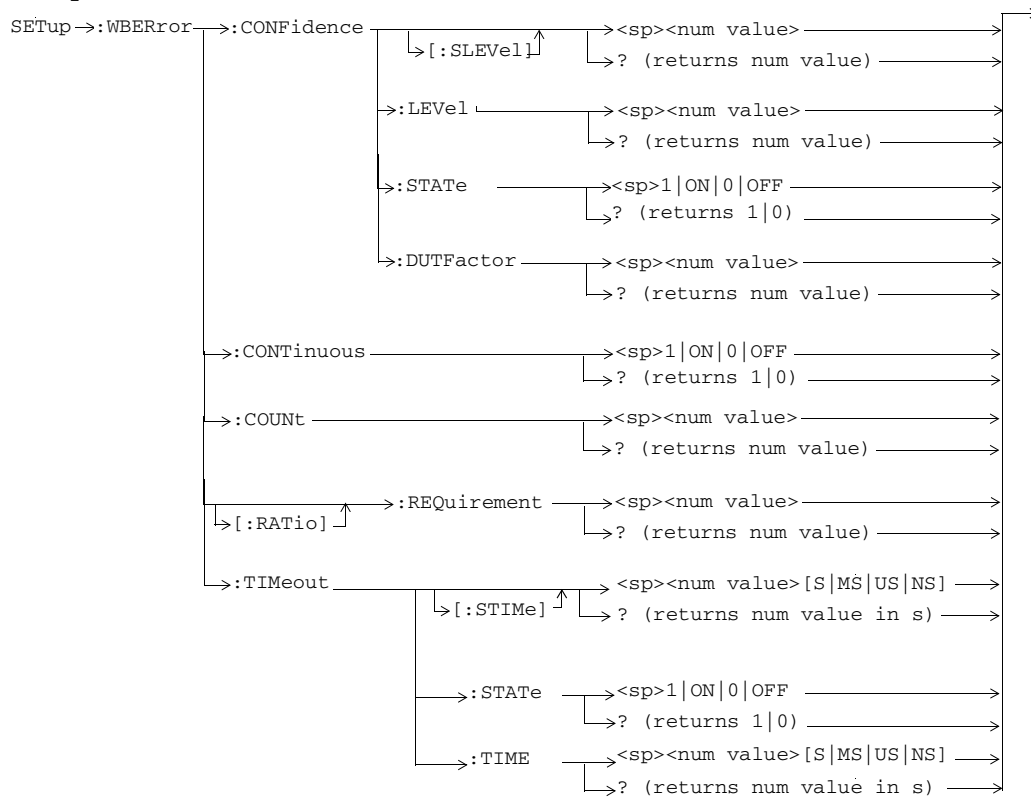

SETup:WBLerror

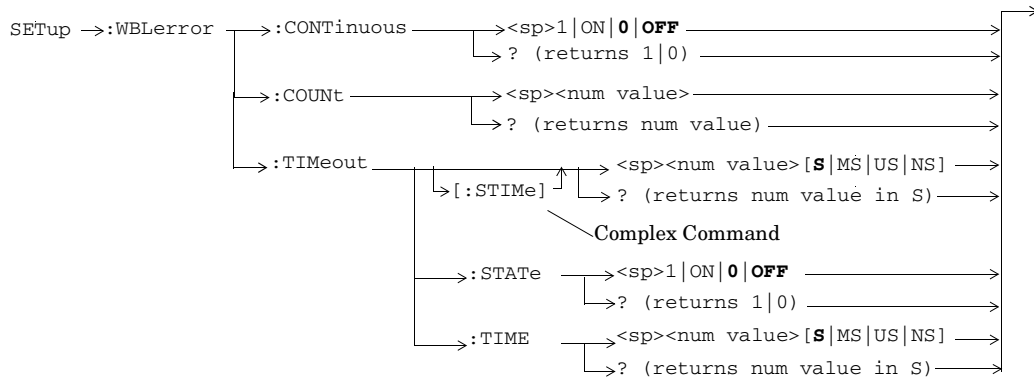

SETup:WCDomain

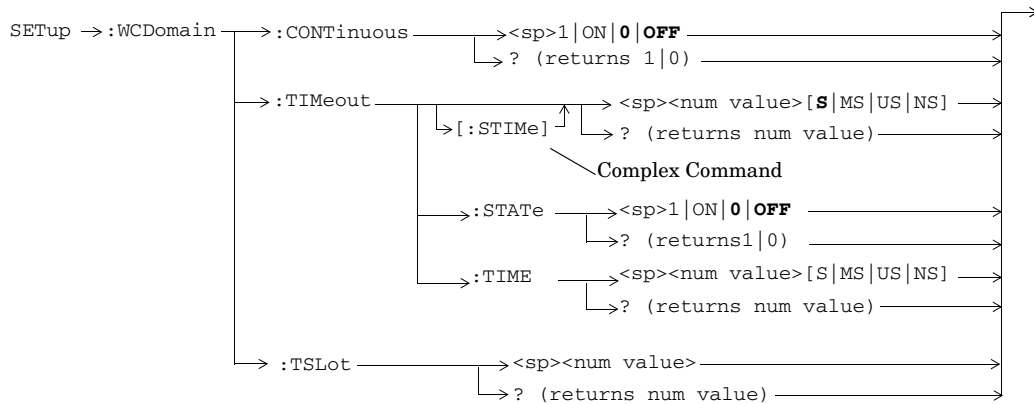

SETup:WCPower

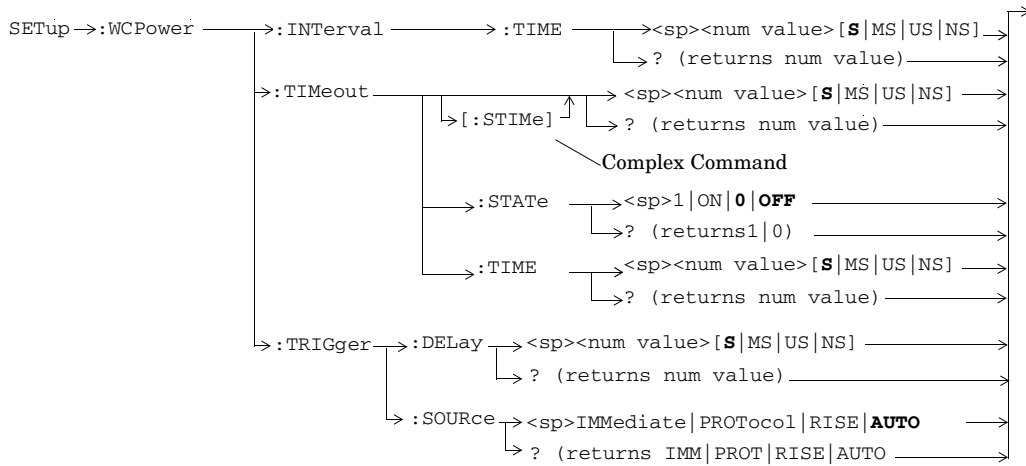
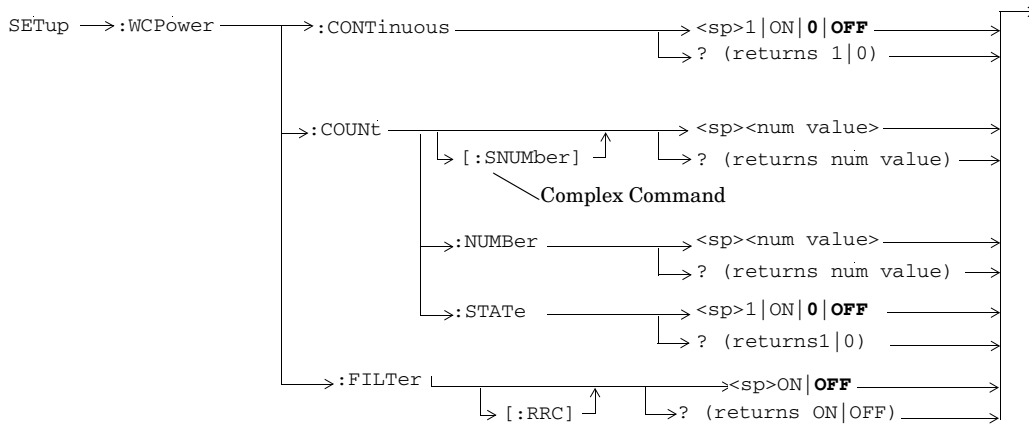

SETup:WCTFormat

This section is only applicable to the lab application.

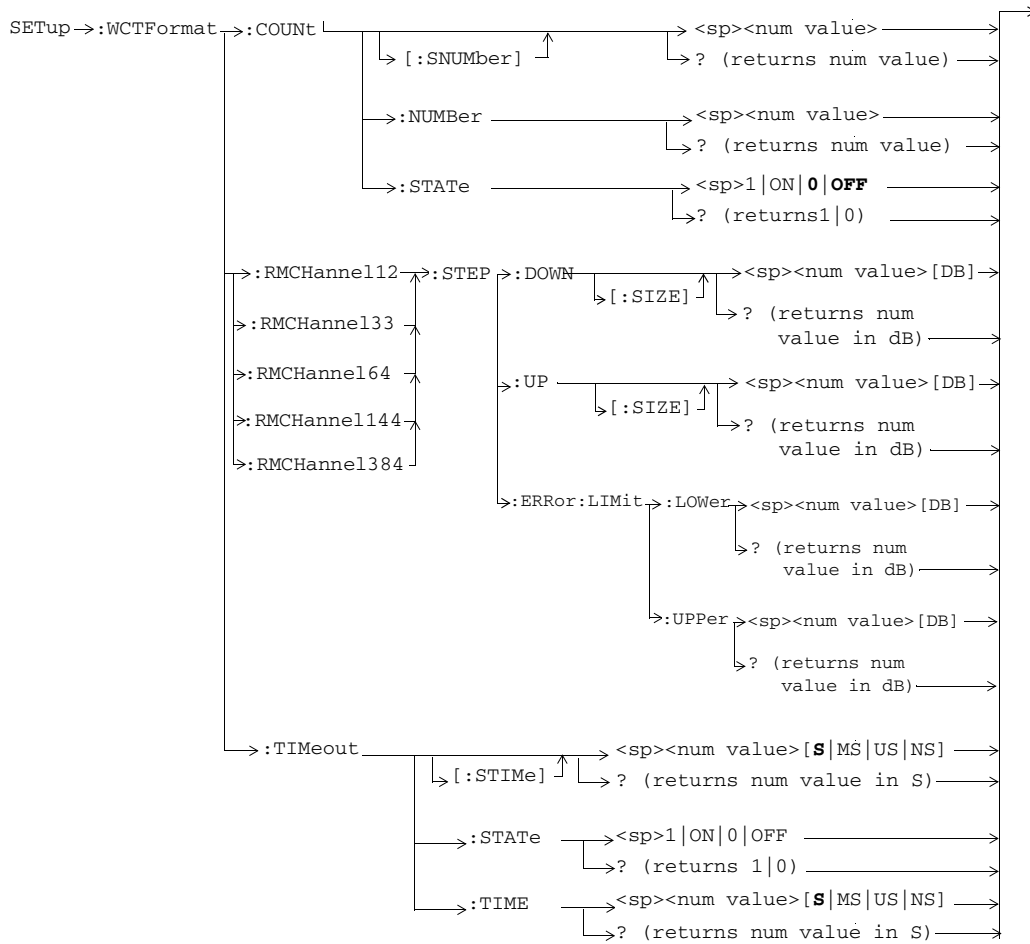

SETup:WDPAnalysis

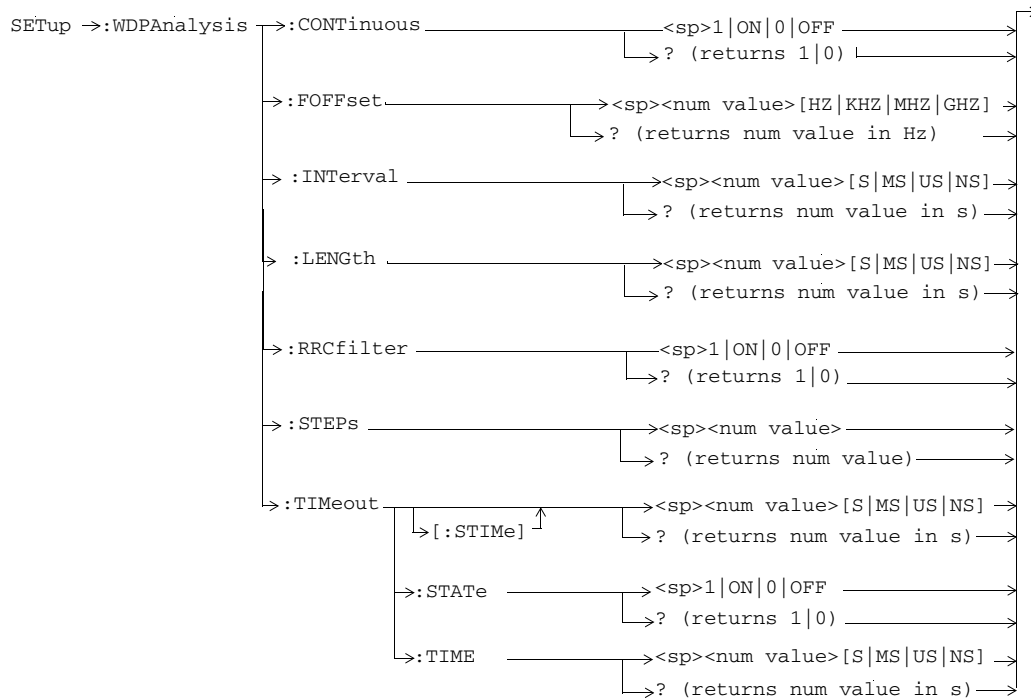

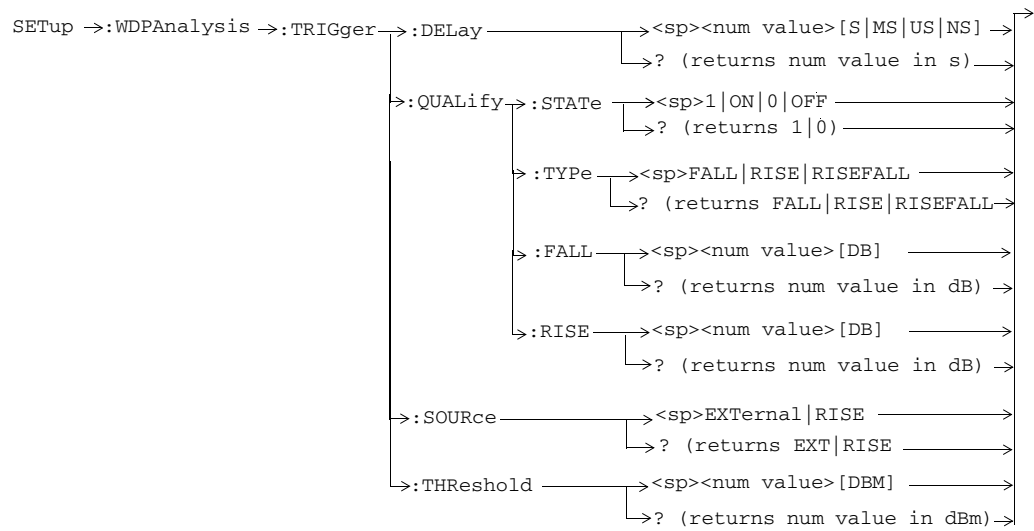

SETup:WILPower

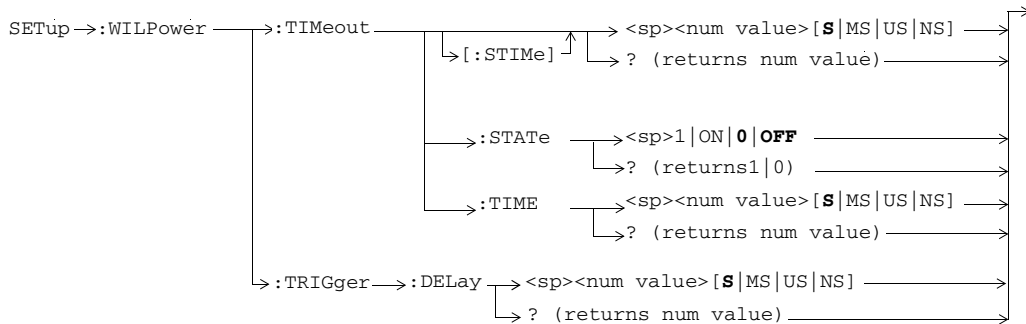
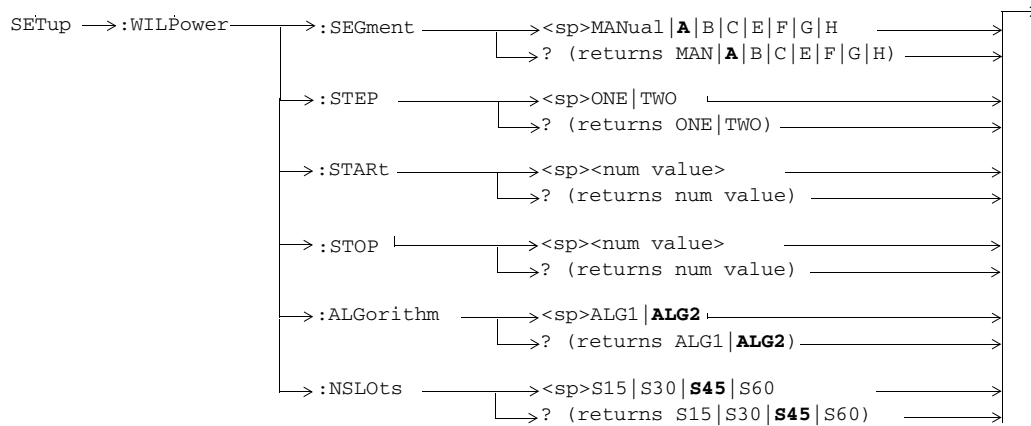

SETup:WIQTuning

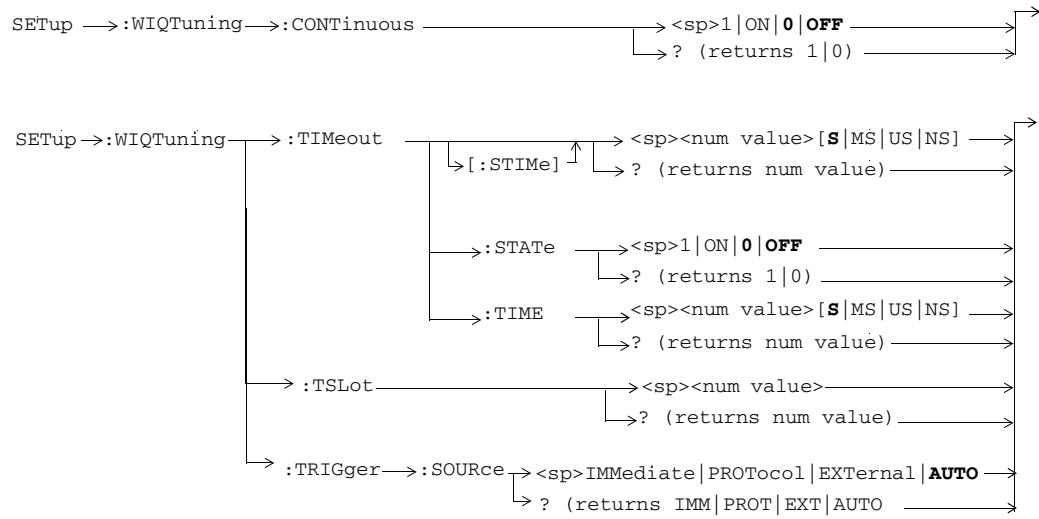

SETup:WOBWidth

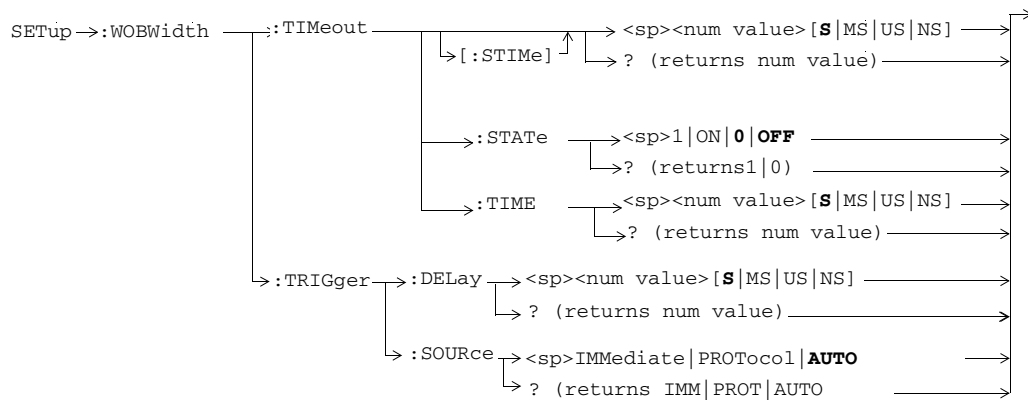
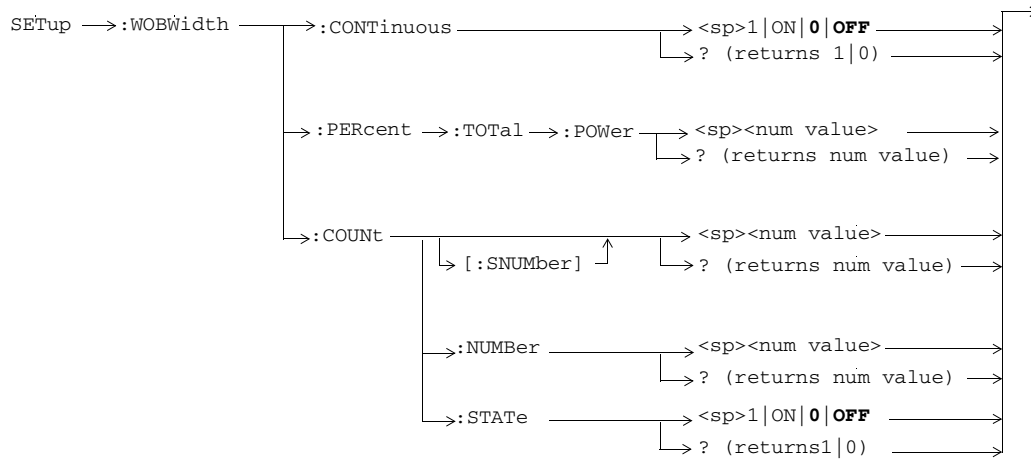

SETup:WOOPower

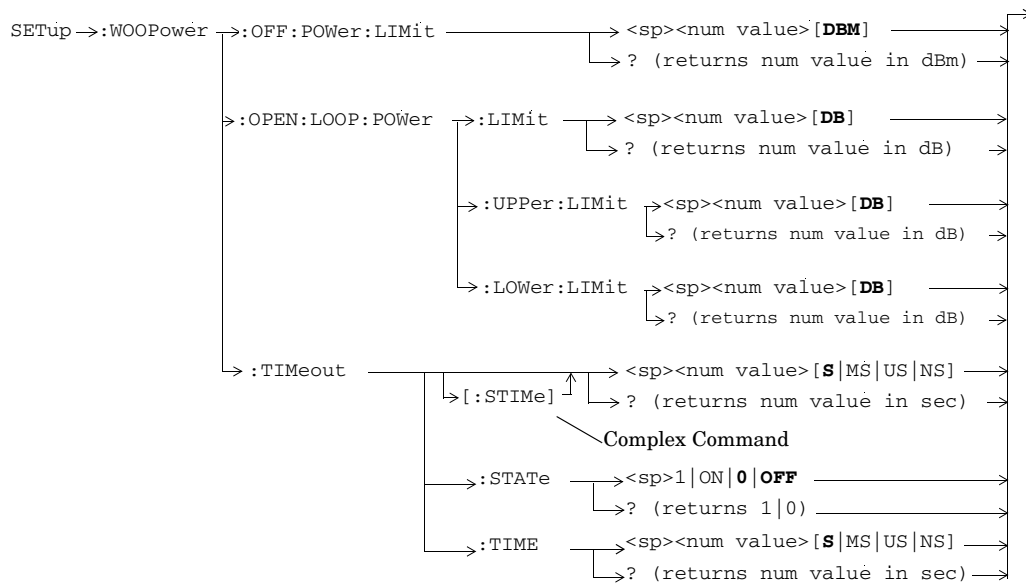

SETup:WOOSynch

This section is only applicable to the lab application.

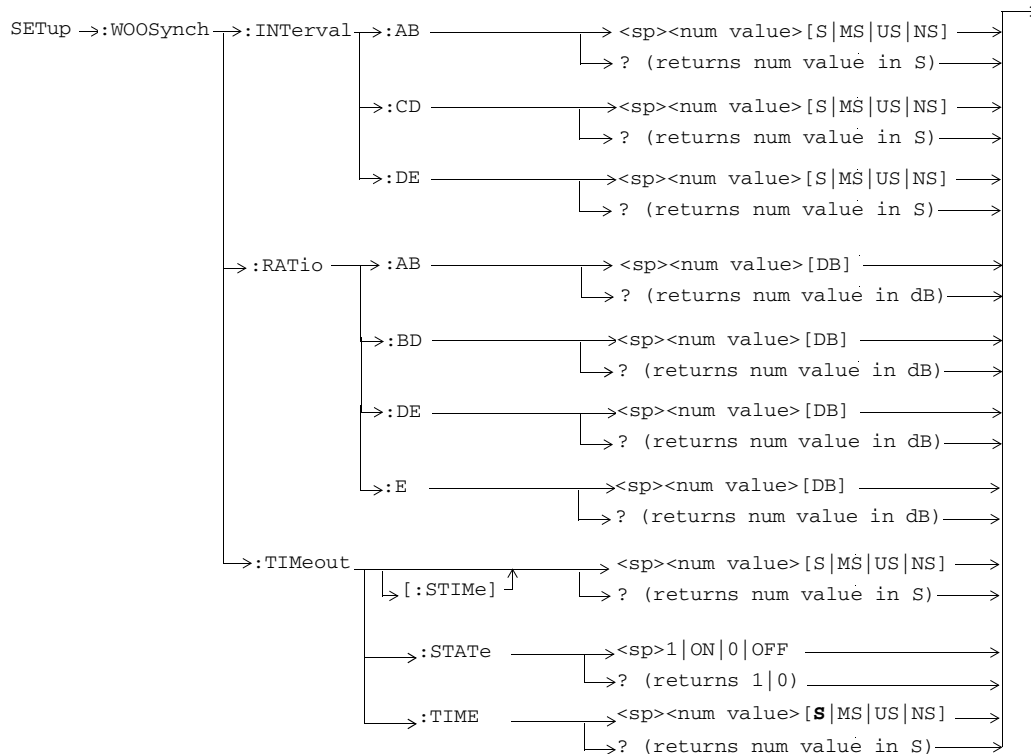

SETup:WPDiscon

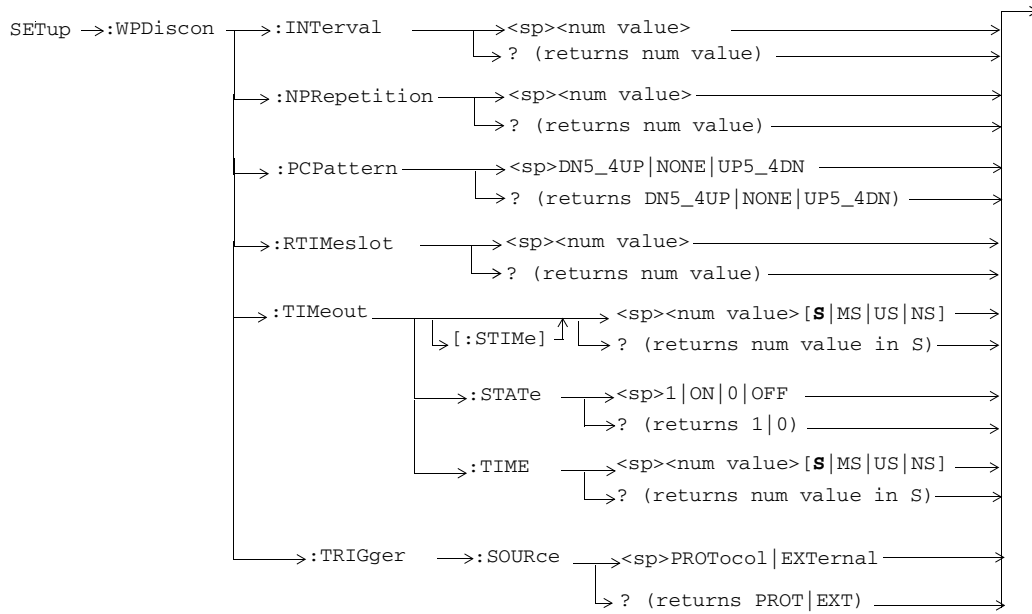

SETup:WPPAnalysis

This section is only applicable to the lab application.

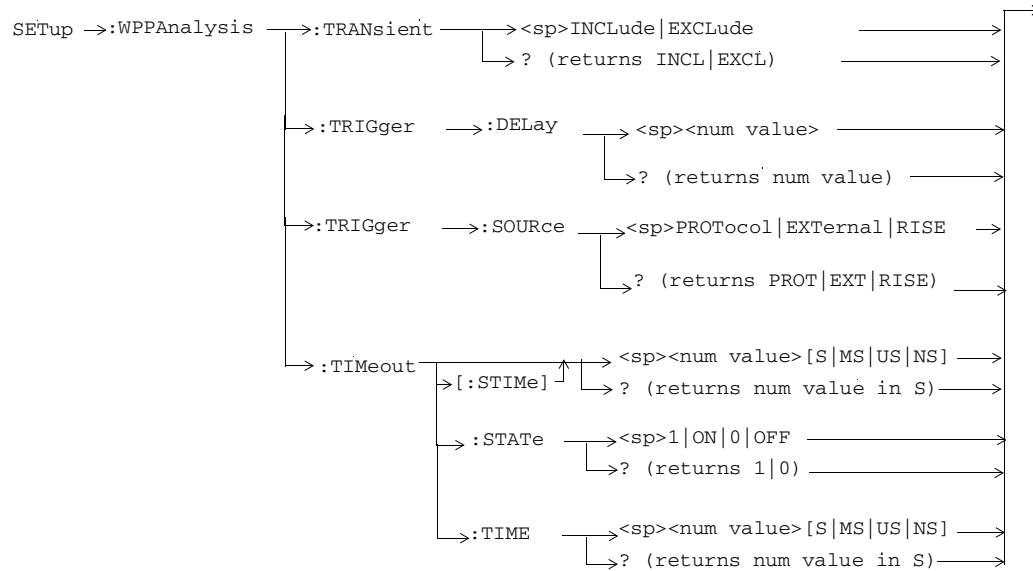

SETup:WSEMask

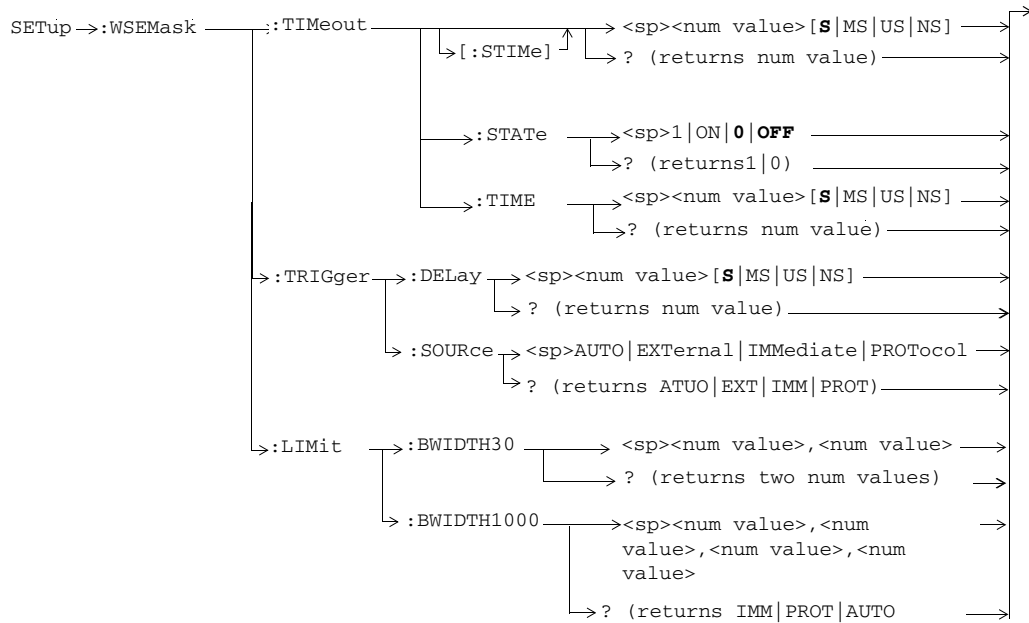
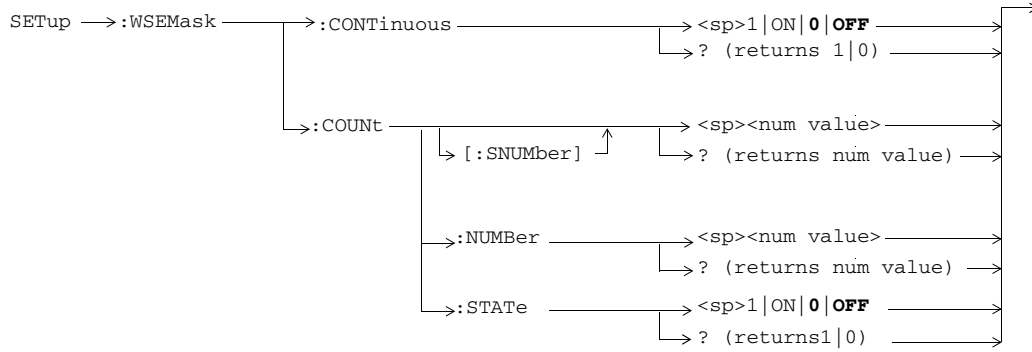

SETup:WTDPower

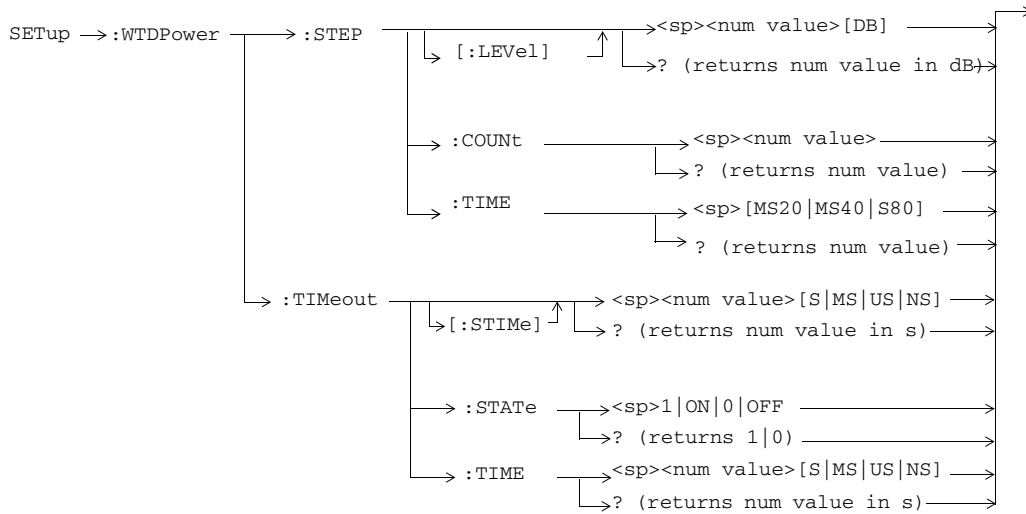

SETup:WTPower

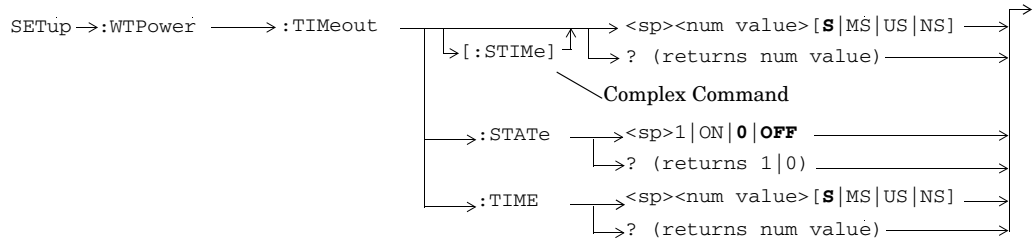
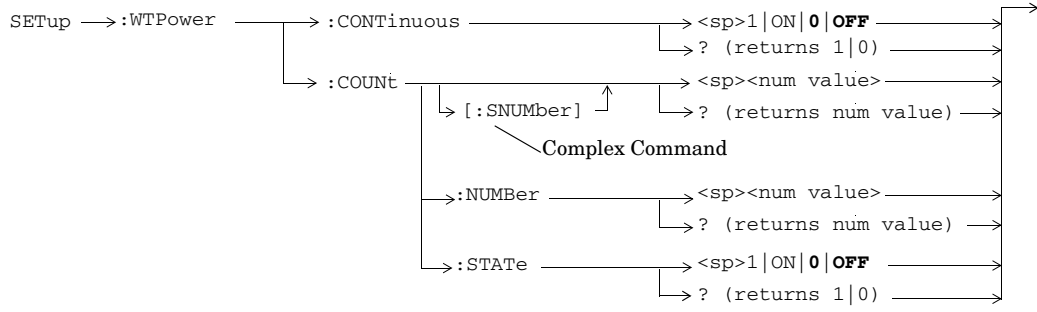

SETup:WWQuality

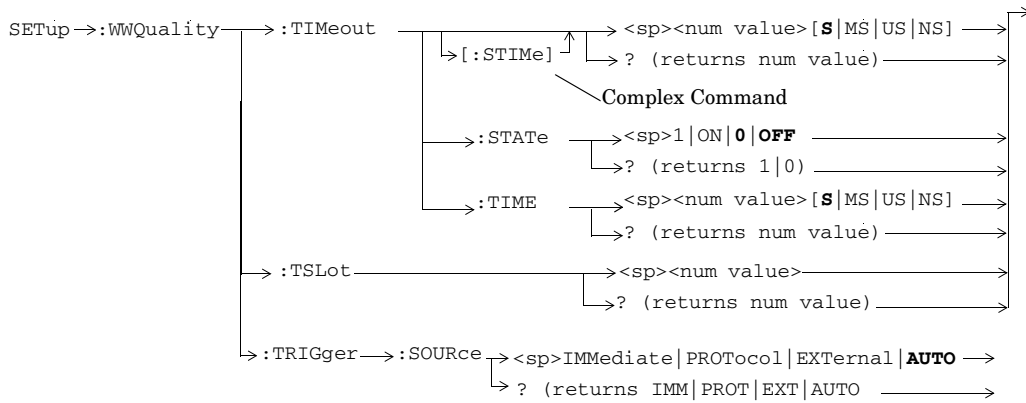
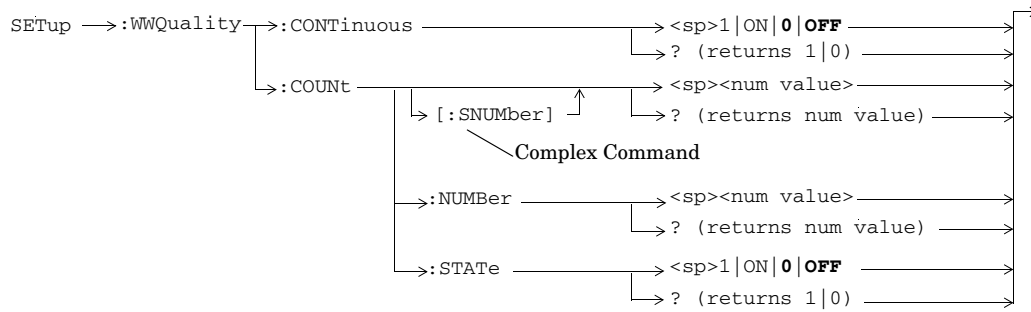

STATUS:OPERation

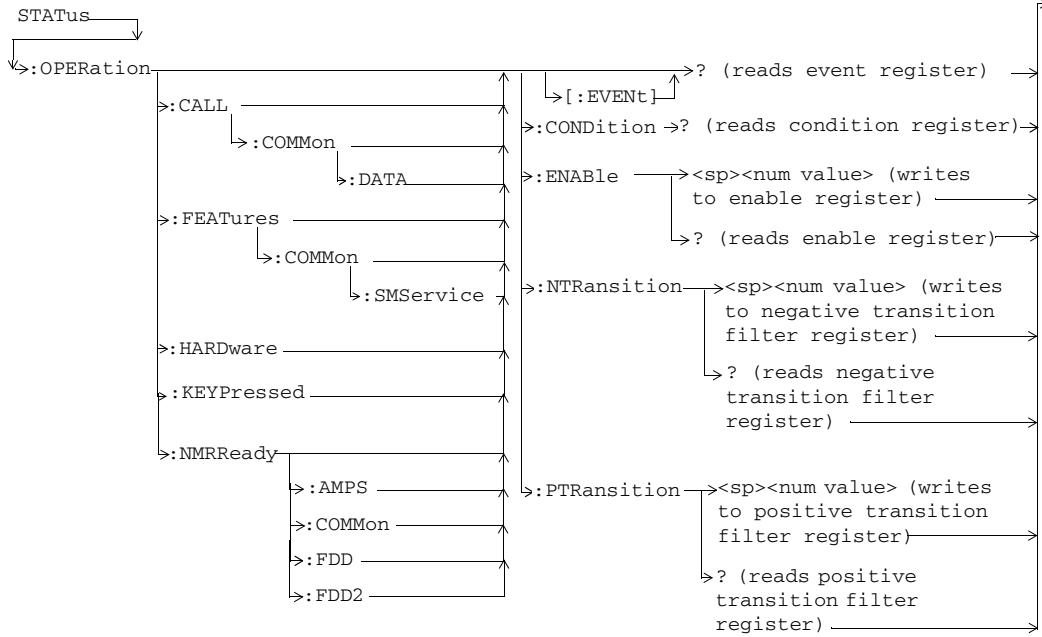

STATUS:PRESet

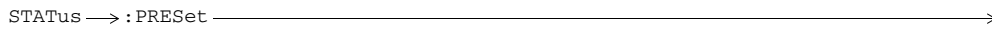

STATUS:QUESTIONable

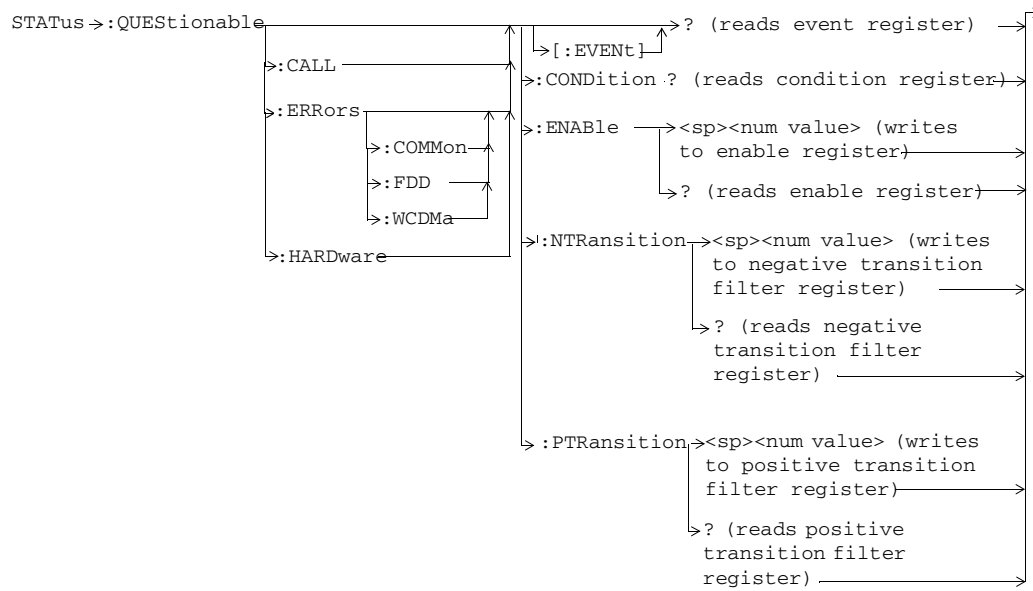

Status Byte Register

*STB?

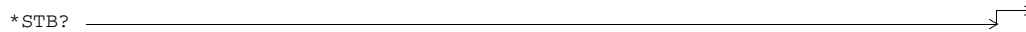

Standard Event Status Register

*ESR?

*ESR? → Reads and clears the Std Event Status Register. →

*ESE?

*ESE? → Reads the Std Event Status Register Enable Register →

*ESE

*ESE → Writes to the Std Event Status Register Enable Register →

SYSTem:APPLication

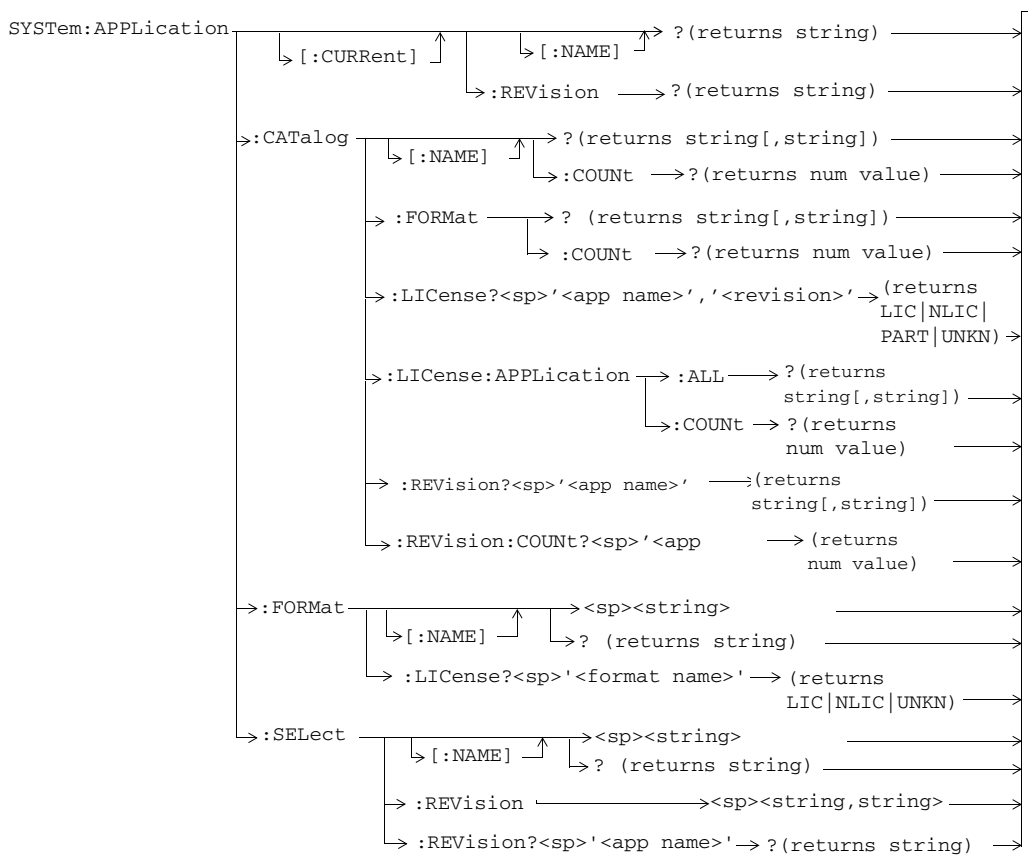

SYSTEM:CONFigure

SYSTEM — :CONFigure —> :INformation —> :HARDware —> :VERBose? —>

SYSTEM:CORRection

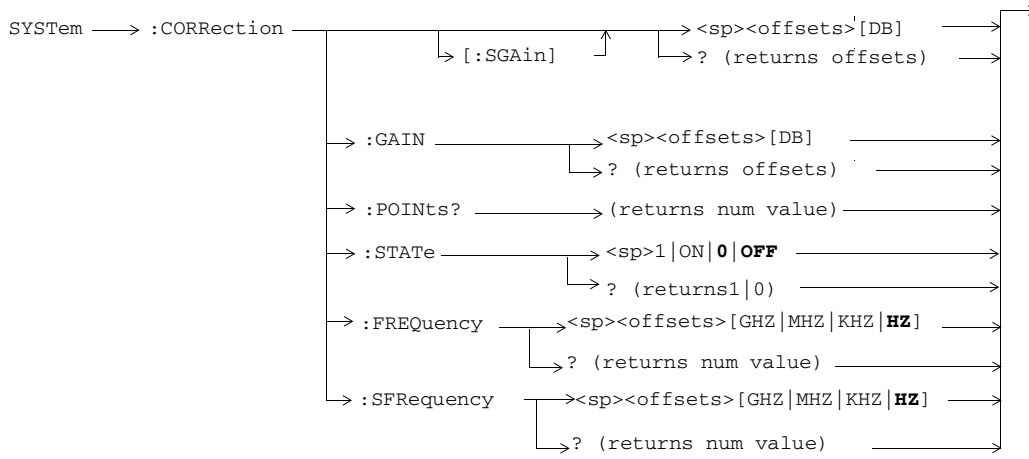

SYSTEM:CURRent:TA

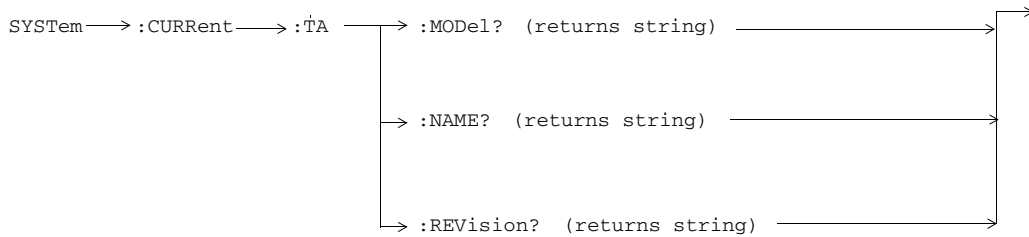

SYSTEM:DATE

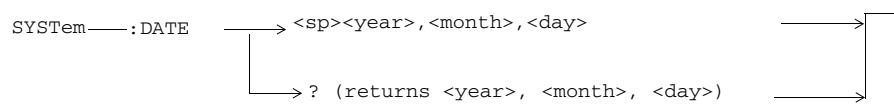

SYSTEM:ERRor?

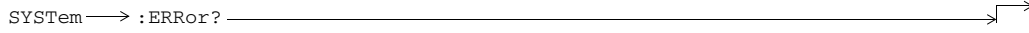

SYSTEM:FATal

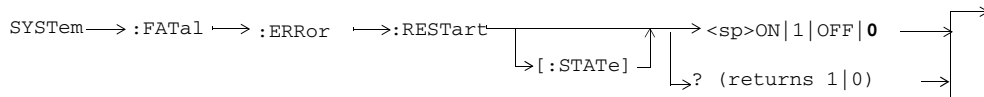

SYSTEM:MEASurement:RESet

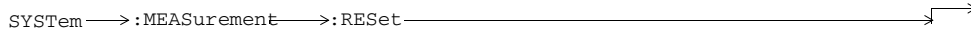

SYSTEM:PRESet

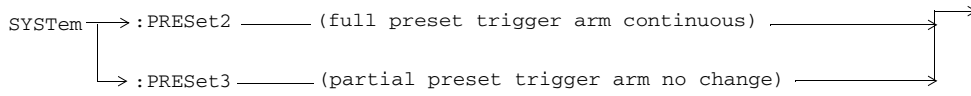

SYSTEM:REGister

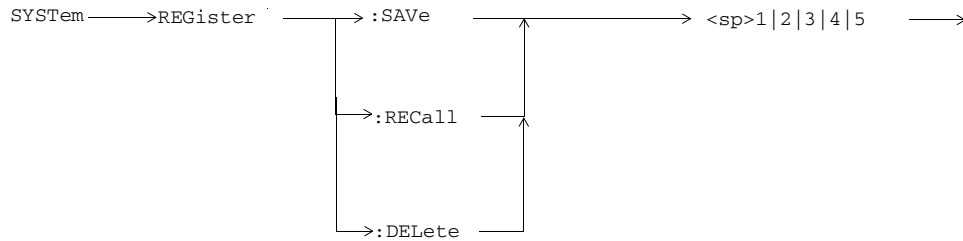

SYSTEM:ROSCillator

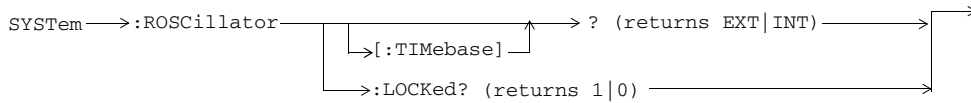

SYSTem:STATus

This section is only applicable to the lab application and to a test application with the required feature license.

```
SYSTem->:STATus:COMMunicate:LAN:EXTernal  
└─[:STATe]┘ ──> ? (returns CONG  
|CONN|DISC|NCON) ──>  
└─:CONNected:ADDRess ->? (returns string) ->
```

SYSTem:SYNChronized

SYSTem——>:SYNChronized? ——> (returns num value) ——>

SYSTem:TIME

SYSTem——>:TIME ——> <sp><hour>, <minute>, <second> ——>
——> ? (returns <hour>, <minute>, <second>) ——>

SYSTem:TZONE

SYSTem——>:TZONE ——> <sp><hour>, <minute> ——>
——> ? (returns <hour>, <minute>) ——>

SYSTem:UTC

SYSTem——>:UTC ——> <sp><hour>, <minute>, <second> ——>
——> [:TIME] ——> ? (returns <hour>, <minute>, <second>) ——>
——> :DATE ——> <sp><year>, <month>, <day> ——>
——> ? (returns <year>, <month>, <day>) ——>

IEEE 488.2 Common Commands

Description

***CLS** The *CLS, clear status command, is defined in “IEEE Std 488.2-1992”, 10.3. This command will also clear and close the error message screen on the test set’s display.

***ESE** The *ESE, standard event status enable command, is defined in “IEEE Std 488.2-1992”, 10.10.

***ESE?** The *ESE?, standard event status enable query, is defined in “IEEE Std 488.2-1992”, 10.11.

***ESR?** The *ESR?, standard event status register query, is defined in “IEEE Std 488.2-1992”, 10.12.

***IDN?** The *IDN?, identification query, is defined in “IEEE Std 488.2-1992”, 10.14. *IDN? is used to retrieve information about the test set in ASCII format.

***IDN?**, returns ASCII codes 32 through 126 excluding comma and semicolon in four comma separated fields. Field 1 returns the manufacturer, field 2 returns the instrument model number, field 3 returns the serial number, field 4 returns 0.

***OPC** The ***OPC**, operation complete command, is defined in “IEEE 488.2-1992”, 10.18. ***OPC** causes the test set to continuously sense the No Operation Pending flag. When the No Operation Pending flag becomes TRUE, the OPC event bit in the standard event status register (ESR) is set to indicate that the state of all pending operations is completed. The ***OPC** common command is not recommended for use as an overlapped command.

***OPC?** The ***OPC?**, operation complete query, is defined in “IEEE Std 488.2-1992”, 10.19. The ***OPC?** query allows synchronization between the controller and the test set using either the message available (MAV) bit in the status byte, or a read of the output **OPC?**. The ***OPC?** query does not effect the OPC event bit in the Standard Event Status Register (ESR). The ***OPC?** common command is not recommended for use as an overlapped command.

***OPT?** The ***OPT?**, option identification query, is defined in “IEEE Std 488.2-1992”, 10.20. Each option will have a unique name, that name will be returned with the query.

***RST** The ***RST**, full preset command, is defined in “IEEE Std 488.2-1992”, 10.32. ***RST** is the recommended command when performing a full preset on the test set. A ***RST** restores the majority of settings to their default values.

- ***RST** sets trigger arm to single
- **PRESet2** sets trigger arm to continuous

***SRE** The ***SRE**, service request enable command, is defined in “IEEE Std 488.2-1992”, 10.34. The parameter range for this command is 0 through 255.

***SRE?** The ***SRE?**, service request enable query, is defined in “IEEE Std 488.2-1992”, 10.35. Values returned by this query range from 0 through 255.

***STB?** The ***STB?**, read status byte query, is defined in “IEEE Std 488.2-1992”, 10.36. Values returned by this query range from 0 through 255.

***WAI** The ***WAI**, wait-to-continue command, is defined in “IEEE Std 488.2-1992”, 10.39. The ***WAI** command prevents the test set from executing any further commands or queries until all pending operation flags are false. The ***WAI** common command is not recommended for use as an overlapped command.

Index

Symbols

+10MHz Offset, 73, 95
+10MHz Offset State, 107
+5MHz Offset, 73, 95
+5MHz Offset State, 107

Numerics

100 Hz BW BPF Center Frequency, 99
-10MHz Offset, 73, 95
-10MHz Offset State, 106
12.2k/33kNC/64k/144k/384k RMC Step Down Size, 111
12.2k/33kNC/64k/144k/384k RMC Step Error Limit Lower, 111
Upper, 111
12.2k/33kNC/64k/144k/384k RMC Step Up Size, 111
-5MHz Offset, 73, 95
-5MHz Offset State, 106

A

Activate PDP Context Reject SM Cause, 49
Activate PDP Context Reject State, 49
Active Cell Status, 26
Adjacent Channel Leakage Ratio, 73, 95
Alternate Ping Address, 31
Amplitude, 11
AMR Radio Access Bearer, 49
Application Selection, 128
Application Setup, 128
Application Switch, 128
Application, Revision, License, 128
ATT (IMSI Attach) Flag State, 13
Audio Analyzer
Audio Frequency, 68, 95
Audio Level, 69, 95
Distortion, 68, 95
SINAD, 69, 95
Audio Frequency, 68, 95
Audio Frequency State, 99
Audio Generator, 11
Audio Generator Coupling, 101
Audio Generator Level, 102
Audio Level, 69, 95
Audio Out Port, 129
Available Subchannels (Bit Mask), 66
AWGN Power, 14
AWGN Power (dBm/1.23 MHz) Desired Level, 14

Aysnc CS Data Source, 49

B

base station originated call, 43
BCCH SIB 11 Cell Info List, 15
BCCH Update Page, 19
BCHARFCN (GSM Measurement Results), 40
Beeper State, 129
BER Requirement, 108
Bit Error Count, 74
Bit Error Ratio, 74
Block Error Count, 74
Block Error Ratio, 74
Blocks Tested, 74

C

Calibrate Measurements, 13
CALL
CPNumber, 30
SMS, 54
call originate, 43
Called Party Number, 41
Cell Identity, 38
Cell LAC, 38
Cell MNC, 39
Cell Power, 46
Cell Power (dBm/3.84 MHz), 46
Cell2 Power, 22
Channel Power, 83, 95
Channel Type, 32, 49
Clear MS Info, 40
CM PCR Timing Indication (CFN Handling), 25
Comp. OCNS, 21, 43
Compressed Mode Meas - UE Setup, 25
Compressed Mode Meas Purpose, 25
Compressed Mode State, 60
Confidence Level, 108
Confidence Test Result, 74
Constant Value, 31
Corrupted Bursts, 28, 29
Coupling, 11
CPICH Ec/No (UE Reported), 40
CPICH RSCP (UE Reported), 40
CPNumber, 30
Current Service Type, 61

D

Data Throughout Monitor, 29
Date (yyyy.mm.dd), 130, 131
Deact Type, 36
Debug State, 129
Decode Errors, 28, 29

De-Emphasis State
Audio Analyzer, 98
Default Gateway, 129
DELETE hardkey, 131
Detected PRACH Signature, 41
Detector Type, 101
Audio Analyzer, 98
Device Settling Time, 102
Device to Ping, 31
Distortion, 68, 95
Swept Audio, 71
DL Chan (Interfreq Measurement Results), 41
DL Channel, 22
DL TFCI Pattern, 37
Downlink Channel Codes
PICH Channelization Code, 45
Primary Scrambling Code, 22, 47
DPCH 12.2 RMC Channelization Code, 33
DPCH 144k RMC Channelization Code, 33
DPCH 240 kspcs Channelization Code, 34
DTCH BLER Report (UE Reported), 40
DUT Factor, 108
DUT IP Address, 39

E

Ec/No (Interfreq Measurement Results), 41
Enable Compressed Mode, 24
Ending CFN, 36
EVM, 75, 89, 95
Execute Handoff, 38
Expander Reference Level, 98
Expected CW Power, 97
Expected Peak Voltage, 99, 101
External Device Conn Status, 132

F

FDD Test CPICH Level, 36
FDD Test DL Channel Levels, 36
FDD Test DPCH Level, 37
FDD Test P-CCPCH/SCH Level, 36
FDD Test PICH Level, 37
FDD Test UL CL Power Ctrl Algorithm, 37
FDD Test UL CL Power Ctrl Mode, 37
FDD Test UL CL Power Ctrl Stepsize, 37
Filter Type, 101
Audio Analyzer, 99

Index

- FM Demodulation Setup
 - Bandpass Filter State, 129
 - Deemphasis State, 129
 - Expander State, 129
- Freq Error (Hz)
 - Minimum, Maximum, Average, 70
- Frequency, 11
 - frequency stability, 70
- Frequency (kHz)
 - Minimum, Maximum, Average, 70
- Frequency (MHz)
 - amplitude offset, 130
- Frequency Error, 70, 75, 89, 95
- Frequency Offset
 - Dynamic Power Analysis, 112
- Frequency Stability
 - Frequency, 70
 - Frequency Error, 70
 - integrity, 70
 - intermediate count, 70
 - Worst Frequency Error, 70
- Frequency Stability Setup
 - Measurement Timeout, 100
 - Multi-Measurement Count, 100
 - Trigger Arm, 100
- FULL (preset) key, 125
- G**
 - GMM State, 60
 - gotolink SEL, 7
 - GPIB Address, 129
 - GPRS Radio Access Bearer, 49
 - GSM 1st Cell Band - 8th Cell Band, 15
 - GSM 1st Cell BCC - 8th Cell BCC, 15
 - GSM 1st Cell BCH ARFCN - 8th Cell BCH ARFCN, 15
 - GSM 1st Cell NCC - 8th Cell NCC, 16
 - GSM 1st Cell State - 8th Cell State, 16
 - GSM RSSI Meas Reporting Interval, 24
 - GSM RSSI Meas Reporting Quantity, 24
- H**
 - Handoff Downlink Channel (UARFCN), 50
 - Handoff RB Test Mode RAB, 50
 - Handoff Uplink Channel (UARFCN), 50
 - Handoff Uplink Separation, 50
- I**
 - IMEI, 41
 - IMSI, 41
 - Initial DPCCCH Tx Power, 65
 - Initial PRACH Tx Power, 66
 - Inner Loop Power, 80
 - Inner Loop Power Control, 95
 - Instrument Information Test Application, 130
 - Instrument Setup
 - Beeper State, 129
 - integrity
 - frequency stability, 70
 - Inter Freq 1st Cell DL Channel - 8th Cell DL Channel, 17
 - Inter Freq 1st Cell Scrambling Code - 8th Cell Scrambling Code, 18
 - Inter Freq 1st Cell State - 8th Cell State, 18
 - Interfreq Meas Reporting Interval, 24
 - Interfreq Meas Reporting Quantity, 24
 - intermediate count
 - frequency stability, 70
 - Intra Freq 1st Cell Scrambling Code - 8th Cell Scrambling Code, 17
 - Intra Freq 1st Cell State - 8th Cell State, 17
 - IP Address
 - Setting DUT, 39
 - IQ Tuning, 95
 - IQ tuning, 81
 - EVM, 81
 - Frequency Error, 81
 - IQ Gain Imbalance, 81
 - IQ Phase Imbalance, 81
 - Magnitude Error, 81
 - Origin Offset, 81
 - Peak Code Domain Error, 81
 - Phase Error, 81
 - Time Error, 81
- L**
 - LAN IP Address, 129
 - Loopback BER, results, 74
 - Loopback Bit Error Ratio, 95
 - Loopback BLER, 74, 95, 109
- M**
 - Magnitude Error, 75, 90, 95
 - Manual Power, 97
 - Manual PRACH Bc, 66
 - Manual PRACH Bd, 66
 - Manual Uplink DPCH Bc, 65
 - Manual Uplink DPCH Bd, 65
 - Max Frames Allowed for Assignment, 28, 29
 - Maximum Uplink Transmit Power Level, 66
 - Measurement Frequency, 97
 - Measurement Frequency (manual), 97
 - Measurement Interval, 110, 114, 116, 121
 - Dynamic Power Analysis, 112
 - Phase Discontinuity, 119
 - MEASUREMENT RESET key, 10, 131
 - Measurement Results
 - Change of TFC, 78
 - Dynamic Power Analysis, 79
 - Phase Discontinuity, 85
 - PRACH Preamble Analysis, 86
 - Measurement Selection, 92
 - Measurement Timeout
 - Adjacent Channel Leakage Ratio, 106
 - Audio Analyzer, 99
 - Change of TFC, 111
 - Channel Power, 110, 114, 116, 121
 - Dynamic Power Analysis, 112
 - frequency stability, 100
 - IQ tuning, 115
 - Loopback Bit Error Ratio, 108, 109
 - Loopback Block Error Ratio, 109
 - Out-of-Synch Handling of
 - Output Power, 118
 - Phase Discontinuity, 119
 - PRACH Preamble Analysis, 120
 - PRACH Transmit On/Off Power, 117
 - Swept Audio, 102
 - Thermal Power, 123
 - TX Dynamic Power, 122
 - Waveform Quality, 124
- Message Log, 131
- Missing Bursts, 28, 29
- MM Status, 60
- MS Loopback Type, 39
- MS Reported Failure Cause, 40
- MS Target Power, 39
- Multi-Measurement Count
 - Adjacent Channel Leakage Ratio, 106
- Audio Analyzer, 98
- Change of TFC, 111

Index

- Channel Power, 110, 114, 116, 121
 - frequency stability, 100
 - Loopback Bit Error Ratio, 109
 - Swept Audio, 101
 - Thermal Power, 123
 - Waveform Quality, 124
- N**
- N313 UE Out-Of-Sync Counter, 19
 - N315 UE In-Sync Counter, 19
 - Number
 - amplitude offset, 130
 - Number of bits to test, 108, 109
 - Number of Blocks to Test, 109
 - Number of Pattern Repetitions
 - Phase Discontinuity, 119
 - Number of Points, 101
 - Number of Power Steps, 122
- O**
- Off Power Limit, PRACH
 - Transmit On/Off Power, 117
 - Offset (dB)
 - amplitude offset, 130
 - Open Loop Power Error Limit,
 - PRACH Transmit On/Off Power, 117
 - Operating Mode, 43
 - Origin Offset, 75, 90, 95
 - originating a call, 43
- P**
- Packet Loss, 31
 - Packets Received, 31
 - Packets Transmitted, 31
 - Pages, 28, 29
 - Pathloss (Interfreq Measurement Results), 41
 - Pathloss (UE Reported), 40
 - PCR Timing Indication (CFN Handling), 38
 - Phase Error, 75, 91, 95
 - PICH Channelization Code, 45
 - Ping, 31
 - Ping Count, 31
 - Ping Setup
 - Alternate Ping Address, 31
 - Device to Ping, 31
 - Ping Count, 31
 - Ping Timeout, 31
 - Ping Timeout, 31
 - Power Class, 41
 - Power Control, 97
 - Power Control Pattern
 - Phase Discontinuity, 119
 - Power Step Size, 122
 - Power Step Time, 122
 - PRACH Bc/Bd Control, 66
 - PRACH Power Step, 66
 - PRACH Preambles, 66
 - PRACH Ramping Cycles, 66
 - PRACH Scrambling Code, 66
 - PRACH Signature, 66
 - PRACH Transmit On/Off Power, 84, 95
 - PRESET key, 125
 - Primary CPICH TX Power, 44
 - Primary Scrambling Code, 22, 47
 - Protocol Logging, 45
 - PS Domain Information, 46
 - Pulse, 11
- R**
- RAC, 46
 - RACHs, 28, 29
 - RB Setup Timing Indication (CFN Handling), 46
 - RB Test Mode RRC State Setting, 49
 - RB Test Mode to GSM Handoff Alerting State, 50
 - Receiver Control
 - Manual Power, 97
 - Measurement Frequency, 97
 - Measurement Frequency (manual), 97
 - Power Control, 97
 - Uplink Frequency, 97
 - Uplink Frequency (manual), 97
 - Reference Timeslot
 - Phase Discontinuity, 64, 119
 - Register recall hardkey, 131
 - Rep Meas Type, 41
 - Rev, License, 128
 - RF Gen Freq, 46
 - RF Gen Freq Ctrl, 28
 - RF In/Out, 97
 - RF IN/OUT Amplitude Offset State, 130
 - RF IN/OUT Amptd Offset, 130
 - RF IN/OUT Amptd Offset Setup, 130
 - RF Out Only, 97
 - RF Output Port, 97
 - RF Rise Trigger Threshold
 - Dynamic Power Analysis, 113
 - Round Trip (ms) min/avg/max, 31
 - RRC Filter
 - Dynamic Power Analysis, 112
 - RRC State, 60
 - RSCP (Interfreq Measurement Results), 41
 - RSSI (GSM Measurement Results), 40
 - RSSI (Interfreq Measurement Results), 41
- S**
- SAVE hardkey, 131
 - Scr Code (Interfreq Measurement Results), 41
 - Send Meas Request, 41
 - Send Step Down TPC Bit Pattern, 21, 23
 - Send Step Up TPC Bit Pattern, 23
 - SINAD, 69, 95
 - Swept Audio, 71
 - SINAD/Distortion Fundamental Frequency, 99
 - SINAD/Distortion State, 99, 102
 - Sintersearch, 19
 - Sintrasearch, 19
 - SMS, 54
 - Soft Handoff State, 61
 - Spectrum Monitor, 95
 - Start Frequency, 101
 - Start Ping, 31
 - Starting CFN, 36
 - Step Length
 - Dynamic Power Analysis, 112
 - Steps
 - Dynamic Power Analysis, 112
 - Stop Frequency, 101
 - Stop Ping, 31
 - Subnet Mask, 129
 - Summary Results
 - Packet Loss, 31
 - Packets Received, 31
 - Packets Transmitted, 31
 - Round Trip (ms) min/avg/max, 31
 - Swept Audio, 71
 - System Type, 64
- T**
- T313 UE Link Reestablishment Timer, 19
 - TCR Timing Indication (CFN Handling), 38
 - Test Application (instrument information), 130
 - Test Signal, 67
 - TG Length (TGL), 25
 - TG Pattern Length (TGPL), 25
 - TG Starting Slot Number (TGSN), 25

Index

- TGPS Definition during Call
 - Setup, 25
- Thermal Power, 88, 95
- Time (hh.mm), 133
- Time Slot, 124
- Time Zone (hh.mm), 133
- Total Number of GSM Cells (GSM Measurement Results), 40
- Total Number of Interfreq Cells (Interfreq Measurement Results), 41
- Total RF Power (dBm/1.23 MHz), 64
- Transient Period
 - PRACH Preamble Analysis, 120
- Trigger Arm
 - Adjacent Channel Leakage Ratio, 106
 - Audio Analyzer, 98
 - Channel Power, 110, 114, 116, 121
 - Dynamic Power Analysis, 112
 - frequency stability, 100
 - Loopback Bit Error Ratio, 108, 109
 - Loopback Block Error Ratio, 109
 - Swept Audio, 101
 - Thermal Power, 123
 - Waveform Quality, 124
- Trigger Delay
 - Adjacent Channel Leakage Ratio, 106
 - Channel Power, 110, 114, 116, 121
 - Dynamic Power Analysis, 113
 - PRACH Preamble Analysis, 120
- Trigger Output Setup, 64
- Trigger Qualification Fall
 - Threshold
 - Dynamic Power Analysis, 113
- Trigger Qualification Rise
 - Threshold
 - Dynamic Power Analysis, 113
- Trigger Qualification State
 - Dynamic Power Analysis, 113
- Trigger Qualification Type
 - Dynamic Power Analysis, 113
- Trigger Source
 - Adjacent Channel Leakage Ratio, 106
 - Channel Power, 110, 114, 116, 121
 - Dynamic Power Analysis, 113
 - Phase Discontinuity, 119
 - PRACH Preamble Analysis, 120
- U**
 - Universal Coordinated Time (UTC), 133
 - Universal Coordinated Time (UTC) Date, 133
 - Uplink Channel, 65
 - Uplink DPCH Bc/Bd Control, 65
 - Uplink DPCH Scrambling Code, 65
 - Uplink DTCH RMC CRC
 - Presence, 49
 - Uplink Frequency, 97
 - Uplink Frequency (manual), 97
 - Uplink Interference, 64
 - Uplink Missing Blocks, 74
 - Uplink Separation, 65
 - Uplink Timing Offset, 66
- W**
 - Waveform Quality, 75, 89
 - Worst Frequency Error, 70